

OCTOBER - NOVEMBER 2021

# BASS

Fishing™



THE

# CHAMPIONS ISSUE



**WE ARE  
BASS FISHING.**



# HYPERSpeed

LEW'S FASTEST REEL EVER

40 inches per handle turn

9.5:1 gear ratio



EXCLUSIVELY AVAILABLE AT



**BIG5**

EXCLUSIVE TACKLE RETAILER OF MLF BIG5





Our Power-Pole Blade Shallow Water Anchor fits in so well with nature you'd almost think it had gills, fins and a tail.



Power-Pole.com

# TABLE OF CONTENTS

OCTOBER-NOVEMBER 2021 | VOL. 20 | ISSUE 6



PHOTO BY JOEL SHANGLE



PHOTO BY CHARLES WALDORF



PHOTO BY JODY WHITE



PHOTO BY PHOENIX MOORE

## COLUMNS

- 22 NEWELL'S NOTES  
— Rob Newell
- 26 BALOG ON BASS FISHING  
— Joe Balog
- 30 BASS SCIENCE  
— TJ Maglio
- 34 TACTICAL BASSIN  
— Matt Allen and Tim Little

## FEATURES

- 38 UNSTOPPABLE WHEELER  
— Joel Shangle
- 44 NEAL GETS HIS  
— Sean Ostruszka
- 50 WASHAM WINS IT!  
— Joe Sills
- 56 MASTERS SERIES  
— Ken Duke

## THE JUICE

- 64 THE TOURNAMENT REPORT  
— Joel Shangle and Justin Onslow
- 68 REVIEW: WILEY X CLIMB  
— Matt Williams
- 72 FALL CRANKBAIT COLORS  
— Tyler Brinks
- 76 GEARING UP: HOT REELS  
— Mason Prince

- 80 Q&A: CLABION JOHNS  
— Kyle Wood
- 83 THE BASS FEDERATION  
— Edited by Mason Prince
- 88 THE LAST CAST  
— Ken Duke

COVER BY BRANDON ROWAN



**WE ARE  
BASS FISHING.™**

We reserve the right to refuse any material we feel is not in the best interest of MLFLW, LLC, (DBA "FLW") and its members/subscribers. The items advertised herein are warranted by the advertiser. Bass Fishing is published six times per year by MLF, 30 Gamble Lane, Benton, KY 42025, 270.252.1000. Kathy Fennel, Executive Vice President and General Manager of MLF. Copyright 2021 by MLF. All rights reserved. None of the content of this publication may be reproduced, stored in any retrieval system, or transmitted in any form or by any means (electronic, mechanical, photocopying, recording or otherwise) without the prior written permission of the publisher. Advertising rates available on request. We welcome manuscripts but will not be held responsible for loss of manuscripts, photos or other materials. All manuscripts should include a self-addressed stamped envelope. Bass Fishing (ISSN 1543-6179) is published six times a year (February/March, April/May, June/July, August/September, October/November, December/January) by MLF, 30 Gamble Lane, Benton, KY 42025. Periodicals Postage Paid at Benton, KY, and at additional mailing office. Rates: one year (6 issues) \$10.00; two years (12 issues) \$20.00; three years (18 issues) \$30.00. POSTMASTER: Send address changes to Bass Fishing, 30 Gamble Lane, Benton, KY 42025. For questions regarding your subscription call 270.252.1000 Monday thru Friday, 8 a.m. - 5 p.m. CT.

Printed in the U.S.A.

POLARIS

# MAKE MORE TIME FOR FISHING



From chasing fish to checking-off chores, Polaris vehicles are engineered to help you have more fun — and get more done. Find hidden lakes and remote streams with industry-exclusive Ride Command featuring GPS mapping. With Turf Mode, you can easily install and take out your dock without tearing-up the grass or delicate shoreline. And when work demands your attention, class-leading capability helps you tackle your to-do list and still have time to get to the water and cast a line.



SEE THE FULL LINEUP OF VEHICLES AT [OFFROAD.POLARIS.COM](https://www.offroad.polaris.com)

WARNING: Polaris off-road vehicles can be hazardous to operate and are not intended for on-road use. Driver must be at least 16 years old with a valid driver's license to operate. ALL riders should always wear helmets, eye protection and protective clothing. Always use seat belts and cab nets or doors (as equipped). Never engage in stunt driving, and avoid excessive speeds and sharp turns. Riding and alcohol/drugs don't mix. All riders should take a safety training course. Call 800.342.2764 for additional information. Check local laws before riding on trails. ©2021 Polaris Industries Inc.

## **MLF Bass Fishing Magazine**

**EXECUTIVE EDITOR** | *Joel Shangle*

**MANAGING EDITOR** | *Justin Onslow*

**PRODUCTION MANAGER AND GRAPHIC DESIGNER** | *Michelle Dowling*

**LEAD DESIGNER AND ILLUSTRATOR** | *Brandon Rowan*

**GRAPHIC DESIGNER AND ILLUSTRATOR** | *Phoenix Moore*

**FIELD EDITOR** | *Matt Williams*

**ASSOCIATE EDITOR AND PRODUCER** | *Mason Prince*

## **MajorLeagueFishing.com**

**SENIOR DIRECTOR, DIGITAL MEDIA** | *Joel Shangle*

**SENIOR MANAGER, DIGITAL PRODUCTION** | *Kyle Wood*

**MANAGING EDITOR** | *Jody White*

**SENIOR MANAGER, DIGITAL EDITORIAL** | *Rachel Dubrovin*

**SENIOR MANAGER, DIGITAL CONTENT DEVELOPMENT** | *Josh Gassmann*

**CONTENT PRODUCER AND EDITOR** | *Rob Matsuura*

**VIDEO CONTENT PRODUCER AND EDITOR** | *Katie Robbins*

**VIDEO CONTENT PRODUCER AND EDITOR** | *Jarrett Johnson*

**VIDEO CONTENT PRODUCER AND EDITOR** | *Darryl Turner*

**MANAGER, DIGITAL CONTENT PROGRAMMING** | *Olivia Fissel*

**MANAGER, DIGITAL CONTENT** | *Ellise Verheyen*

**SOCIAL MEDIA SPECIALIST** | *Garrett Chapman*

## **Major League Fishing**

**PRESIDENT AND CEO** | *Jim Wilburn*

**PRESIDENT AND CEO, MLFLW** | *Boyd Duckett*

**EXECUTIVE VICE PRESIDENT AND GENERAL MANAGER** | *Don Rucks, Tulsa, Okla.*

**EXECUTIVE VICE PRESIDENT AND GENERAL MANAGER** | *Kathy Fennel, Benton, Ky.*

**SENIOR VICE PRESIDENT, SPONSORSHIP AND MEDIA SALES** | *Randy Gerstenblatt*

**VICE PRESIDENT OF BROADCAST PRODUCTION** | *Randy White, Tulsa, Okla.*

**VICE PRESIDENT OF OPERATIONS** | *Todd Walker, Tulsa, Okla.*

**VICE PRESIDENT OF OPERATIONS** | *Dave Washburn, Benton, Ky.*

**VICE PRESIDENT OF MARKETING AND BUSINESS DEVELOPMENT** | *John Acosta*

**DIRECTOR OF SPONSORSHIP SALES** | *Chris Bork, Memphis, Tenn.*

*chris.bork@majorleaguefishing.com*

901.229.4797

**DIRECTOR OF ACCOUNT SERVICES** | *Jenn Sonnek*

*jenn.sonnek@majorleaguefishing.com*

651.235.4770

**LOWRANCE®**

[www.lowrance.com](http://www.lowrance.com)

# ACTIVE TARGET™ LIVE SONAR



HIGHEST RESOLUTION LIVE SONAR

FORWARD, DOWN AND SCOUT VIEWS

EASY TO USE AND SEE THE FISH - LIVE!

**GAME ON!**

COMPATIBLE WITH

**HDS LIVE**

**HDS**  
CARBON

**ELITE FS**

## THE MEMORY OF AN ANGLER

The memory of a bass angler is an incredible thing. We may not always remember what we had for lunch yesterday or where we left our truck keys or – heaven forbid – our wedding anniversary, but there’s one thing you can almost universally count on when it comes to a conversation with an angler (be it a seasoned tournament vet or a weekend warrior): The memory of fish catches and all the details surrounding them are as clear and vivid as if they just happened.

Ask anyone who’s ever wielded a rod with some regularity where and when they caught their biggest bass or the circumstances of their most memorable catch. Heck, ask a tournament angler how they filled out their limit on any day of any random tournament. What you’re likely to get is a recitation of all the details, mundane and otherwise. *I got on a good dock pattern that day – isolated docks near deep water – and pitched a green pumpkin Pit Boss up near the third post from the back of a pretty long one with cables in the back where I broke off a good one the day before. I let it fall for a split second on slack line and – BAM – set the hook and had me wrapped around a piling. Got her out, though. I think I had about 14 1/2 pounds with that 4-pounder.*

“Think.” Most any bass angler knows it was 14 1/2, even if that 4-pounder was actually about 3 1/4. Just because we have great memory for detail doesn’t mean we always tell the whole truth.

In the bass fishing world, everything is remembered and recorded and chronicled. We remember because it’s important to us to remember – to learn, to adapt, to always have record of something that brought us joy. Bass fishing certainly does just that for a great many of us.

And just as bass aficionados chronicle their catches, we here at *MLF Bass Fishing* magazine do the same with our anglers. Those anglers teach us, help us adapt and grow as bassers and, yes, they bring us joy. As such, we remember them, we record their feats and we celebrate their successes, always.

In this “champions issue,” you’ll find articles dedicated to the tournament pros who gave us something to remember this year, from Bass Pro Tour champion Jacob Wheeler to Tackle Warehouse Pro Circuit Angler of the Year Michael Neal, TITLE champ Jimmy Washam and Polaris Rookie of the Year Clabion Johns. It’s a lot of celebratory content, and it’s all incredibly important. It’s important to learn what it takes to be a champion, and that every angler finds success in different ways, and it’s important to celebrate those who keep the sport of bass fishing moving in the right direction.

Our champions give us something else to remember, and this issue gives us another way to remember them. And if you need another reason to keep this issue out on your coffee table for a while, maybe use it as a place to keep your truck keys (and a sticky note inside the cover with your anniversary – just in case).



JUSTIN ONSLOW, MANAGING EDITOR

Strike King  
S

STRIKE KING PRO ANGLER / JEFF SPRAGUE



STRIKE KING PRO ANGLER / ANDY MONTGOMERY

# LEAVE TO NOTHING CHANGE

“

My line is the absolute most critical tool that connects me to the fish I'm chasing! Don't cut corners ... spool up some CONTRA and set the hook like a beast!

”

“

Never have I had more confidence in the most direct connection from me to success! Toughness, sensitivity & value all wrapped into the best fluorocarbon I have ever used.

”



## NEW CONTRA PERFORMANCE FISHING LINE

For the past year, the new CONTRA performance fishing line has been tested and proven across the country by top pros on the tournament trail. Consisting of a new formulation, CONTRA delivers reliable performance at a reasonable cost. Grab some, spool it up & see for yourself!

FLUOROCARBON

BRAID

MONOFILAMENT



*Arthur's Seat*  
RO  
NI



2021

idence

AE

RY  
Team

TRCcovers.com  
Florida Fish Production

KOVERT  
TUNGSTEN

STOP





CONSISTENTLY EXCELLENT



### Michael Neal, 2021 Pro Circuit Angler of the Year

Michael Neal's angling career has been as consistent as the Tennessee River currents that helped shape his love for fishing. By age 20, Neal was already competing and succeeding at the professional level, thanks to the mentorship he received while growing up in a family of Tennessee Valley anglers. Over nine years, thousands of road miles, dozens of tournaments and untold bass caught since then, Neal has progressed steadily forward. Always advancing. Constantly carving a path toward where he is today: the 2021 Pro Circuit Angler of the Year. *Congratulations, Michael. Mercury is proud to help power your career.*



[MercuryMarine.com/ProXS](https://MercuryMarine.com/ProXS)



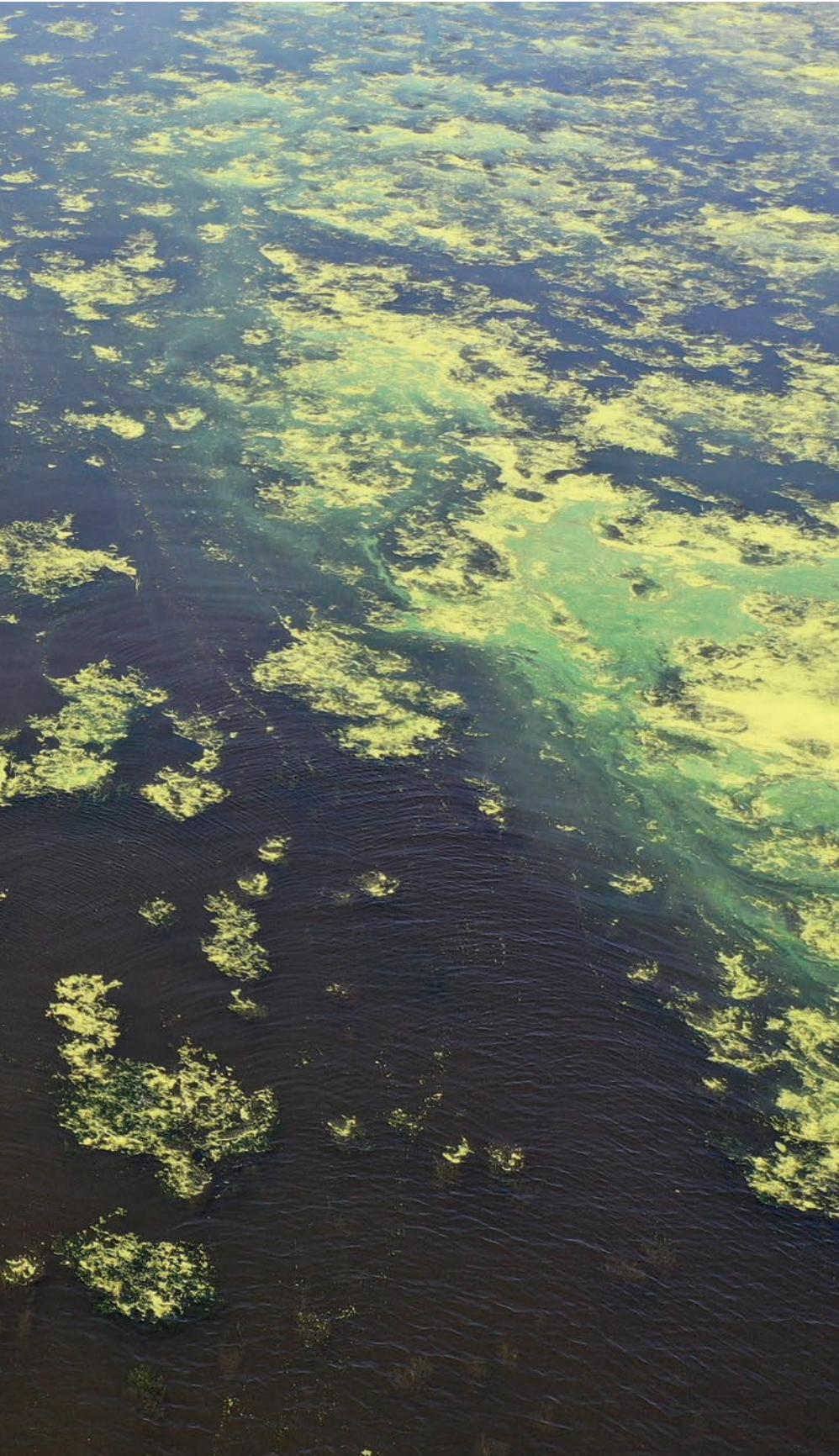

## GOLD AMONG THE GREEN

**W**hen it comes to bass fishing, the Upper Mississippi is a veritable gold mine. Whatever you like – largemouth or smallmouth, rocks, wood, current, grass, flipping or winding – the pools that played home to the 2021 Tackle Warehouse TITL offer those things, and so much more. You may not find many trophy-sized bass in the multi-faceted waters around La Crosse, Wisconsin, but the Mighty Mississippi sure shines for its sheer quantity of multiple species of bass.

Many anglers – like Tackle Warehouse Pro Circuit rookie Cody Pike, pictured here – tend to hunt for their gold among the green on the Mississippi. Frogging and flipping the varied vegetation just makes sense, like taking a drink of water when you’re thirsty.

Pike ended up finishing 41st, but Zack Birge (third), Mitch Crane (fourth), Skeet Reese (fifth), Josh Weaver (sixth) – the list goes on – all took advantage of the many types of grass the Mississippi has to offer, from submerged eelgrass and coontail to duckweed, leaning on a hodgepodge of techniques along the way to get the job done.

As the old saying goes, when in Rome, do as the Romans do. And when on the Upper Mississippi... well, grab a frog rod or a flipping stick and go find some grass.

PHOTO BY ROB MATSUURA





## RODEO RIDE ON ST. CLAIR

---

**W**e've always thought there was a little bit of bull rider blood pumping through Jason Lambert's veins. The Tennessee pro has long been one of the most tenacious anglers on tour – you have to have some bulldog-level determination to win six tour-level tournaments on the Tennessee River – but Lambert went for a rougher ride than usual during the final Bass Pro Tour event of the 2021 season, on Michigan's Lake St. Clair.

Even though competitors were allowed to trailer their boats to various ramps throughout the St. Clair system on a couple of days when the winds gusted over 40 mph, that still didn't provide a free pass for anglers like Lambert to run across the rugged waters of the main lake. They still had to buck the waves to get from Point A to Point B in search of those notoriously nomadic smallies.

And as you can clearly see, some of it was tough sailing (er, motoring).

Lambert racked up 55 pounds of smallmouth on this particular day to climb from below the cut line into the Top 15. His chiropractor might not agree, but it seems this rodeo ride was worth it.

PHOTO BY JOSH GASSMANN



## SOLUNAR TABLES

NOVEMBER-DECEMBER 2021

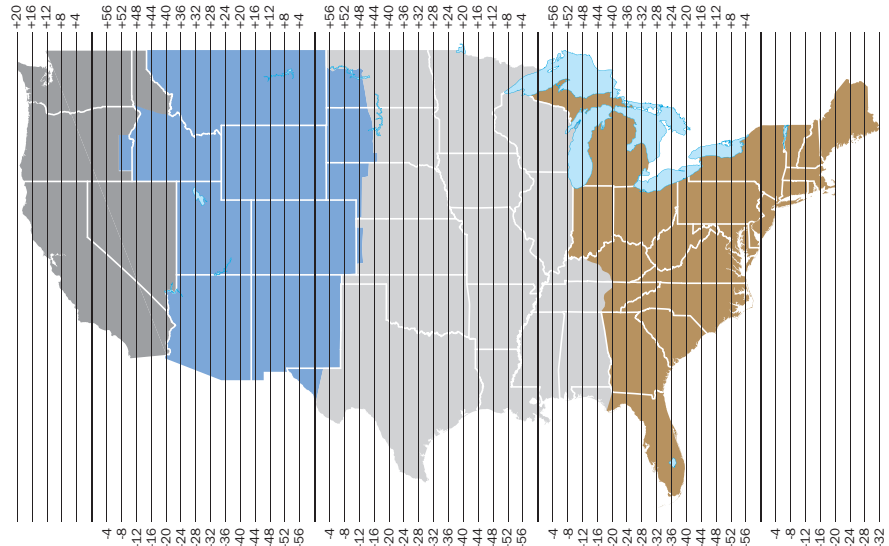

NOV. Date	Day	AM Minor	AM Major	PM Minor	PM Major	Moon Phases	DEC. Date	Day	AM Minor	AM Major	PM Minor	PM Major	Moon Phases
1	Mon	1:30	7:35	1:45	8:00		1	Wed	1:45	7:50	2:00	8:15	
2	Tue	2:15	8:20	2:30	8:45		2	Thu	2:30	8:40	2:50	9:05	
3	Wed	3:00	9:05	3:15	9:30		3	Fri	3:20	9:30	3:40	10:00	
4	Thu	3:45	9:50	4:00	10:20	●	4	Sat	4:15	10:30	4:40	11:00	●
5	Fri	4:35	10:50	5:00	11:20	●	5	Sun	5:15	11:40	5:50	—:—	●
6	Sat	5:35	11:55	6:05	—:—	●	6	Mon	6:30	12:15	7:05	12:50	●
7	Sun	6:40	12:30	7:20	1:05	●	7	Tue	7:35	1:25	8:10	1:55	●
8	Mon	7:50	1:40	8:25	2:10	●	8	Wed	8:40	2:30	9:15	3:00	●
9	Tue	9:00	2:50	9:35	3:20	●	9	Thu	9:40	3:30	10:10	3:55	●
10	Wed	10:05	3:55	10:35	4:20	●	10	Fri	10:35	4:25	11:05	4:50	●
11	Thu	11:05	4:55	11:30	5:15	●	11	Sat	11:25	5:15	11:50	5:35	●
12	Fri	11:50	5:40	—:—	6:05	●	12	Sun	—:—	5:55	12:05	6:15	●
13	Sat	12:20	6:25	12:35	6:50	●	13	Mon	12:30	6:35	12:45	6:55	●
14	Sun	1:05	7:05	1:15	7:25	●	14	Tue	1:10	7:10	1:20	7:30	●
15	Mon	1:40	7:45	1:55	8:05	●	15	Wed	1:45	7:50	2:00	8:10	●
16	Tue	2:20	8:20	2:30	8:40	●	16	Thu	2:25	8:30	2:40	8:50	●
17	Wed	2:55	9:00	3:10	9:20	●	17	Fri	3:05	9:10	3:20	9:35	●
18	Thu	3:35	9:40	3:50	10:00	●	18	Sat	3:50	9:55	4:05	10:20	●
19	Fri	4:15	10:20	4:30	10:45	●	19	Sun	4:35	10:40	4:50	11:05	●
20	Sat	5:00	11:10	5:20	11:35	●	20	Mon	5:20	11:35	5:45	—:—	●
21	Sun	5:50	—:—	6:15	12:00	●	21	Tue	6:15	12:05	6:45	12:30	●
22	Mon	6:40	12:30	7:10	12:55	●	22	Wed	7:05	12:55	7:40	1:25	●
23	Tue	7:35	1:25	8:05	1:50	●	23	Thu	8:00	1:50	8:30	2:15	●
24	Wed	8:30	2:20	9:00	2:45	●	24	Fri	8:50	2:40	9:20	3:05	●
25	Thu	9:25	3:15	9:55	3:40	●	25	Sat	9:40	3:30	10:10	3:55	●
26	Fri	10:15	4:05	10:45	4:30	●	26	Sun	10:30	4:20	10:55	4:40	●
27	Sat	11:05	4:55	11:35	5:20	●	27	Mon	11:20	5:10	11:45	5:30	●
28	Sun	11:50	5:40	—:—	6:00	●	28	Tue	—:—	5:50	12:00	6:15	●
29	Mon	12:15	6:20	12:30	6:45	●	29	Wed	12:30	6:35	12:45	7:00	●
30	Tue	1:00	7:05	1:15	7:30	●	30	Thu	1:15	7:25	1:35	7:50	●
							31	Fri	2:05	8:15	2:25	8:45	●

SOLUNAR TABLES® are designed to forecast the daily active feeding periods of fish. They are formulated from the position of the earth in relation to the sun and moon.

The major periods last for approximately 2 to 3 1/2 hours, and the minor periods last for approximately 3/4 to 1 1/2 hours. To determine the start of major and minor times for your area, find the bold time-zone rule on the map. If you are located in the area left of the time-zone rule, add the number (in minutes) at the top to the corresponding time on the chart. If you are located in the area right of the time-zone rule, subtract the number (in minutes) at the bottom from the corresponding time on the chart. Add one hour to all times during daylight saving time.



Ott DeFoe  
MOSSY OAK FISHING



# MOSSY OAK FISHING

OBSESSION HAS NO OFF-SEASON.  
HUNT. FISH. REPEAT.

HUNTING, FISHING AND OUTDOOR VIDEOS ON YOUR FAVORITE DEVICE. ALWAYS FREE. DOWNLOAD NOW.





## THE SCIENCE OF FISH CARE

How Anglers and Tournament Organizations Can Help Ensure Healthy Fish

### IN A RECENT FEATURE ARTICLE POSTED ON THE MLF

Fisheries Management Division (FMD) section on the MLF website, veteran angler Gary Klein outlined some of the history of tournament bass fishing. In that piece, he reminded us that early bass tournaments began with 15-fish limits that were brought in on stringers, with a 100 percent mortality rate.

It was 1972 – long before catch-and-release tournaments were born and another year before the first aerated livewell became standard in a bass boat.

Since those early days of tournament fishing, the evolution of fish care has been driven by innovation, research, trial and error and harvest regulations. Eventually, it led us to the early 1990s, when the five-fish limit and 90-plus percent live release rate became the standard for bass fishing.

This evolution continued again in 2010, when MLF put its stamp on fish care by using the catch, weigh, immediate-release competition format. This format has become the gold standard in fish care today.

### CONTINUING TO ENHANCE FISH CARE

Fish care is extremely important to MLF – so much so that it's one of the four essential pillars of the MLF Fisheries Management Division. It's a broad topic that can be viewed under several

lenses, depending on if you're an angler, a tournament organization or a fisheries manager.

Anglers have three opportunities to impact the health of a fish: during the retrieval, handling the fish while out of the water and transporting the fish in a livewell.

Tournament organizations also have three potential opportunities to put fish care into practice: during the weigh-in, holding the fish post-weigh-in and then releasing the fish back into the fishery. Over roughly 60 years, anglers and organizations have worked to perfect all these aspects so that we no longer expect mortality and can instead focus on ensuring each fish is thriving.

Due to our collective ability to care for fish, the biologists who manage our fisheries are no longer as concerned with an individual fish; instead, they focus on the management of the entire population. They use long-term trends to determine reproductive success, growth rates, habitat usage and annual mortality. Most fisheries are managed to maximize the growth of juvenile bass to a catchable size, which in turn increases the likelihood of angler success.

Very few fisheries are managed to protect those catchable-size bass to ensure that they reach a quality or trophy-size class. Some very specific species fit into a regionally threatened category and require special regulations to protect them from overexploitation.



PHOTO BY PHOENIX MOORE



## FISH CARE FROM AN ANGLER'S PERSPECTIVE

For most fans, the act of catching, unhooking and releasing a fish needs no review, but for any fans new to fishing, this is a comprehensive summary of the best practices for retrieving and handling a fish.

Fish care technically begins at the bite, as setting the hook engages that fish into being retrieved by the angler. Using the appropriate gear to retrieve the fish with minimal exhaustion is the best way to ensure that the fish can recover quickly. In other words, make sure your hooks, line, rod and reels are all appropriately sized and maintained to get the fish to the boat quickly.

Once you get the fish to your boat, you should always use your thumb to grasp the fish by the lower jaw. If it's a larger fish or you're concerned with how the fish is hooked, you should use a rubber-coated net or wet hands to cradle the body of the fish to remove it from the water. Wetting your hands is a very important step as it helps to minimize bacterial transfer from your hands to the fish.

You should never attempt to land a fish by swinging it into the boat and purposely landing it on your flooring. This will result in the loss of the slime coat on the exterior of the fish (and your fishing partner yelling "Two-minute penalty!").

Once the fish is in the boat, quickly assess how and where the fish is hooked. If it's in any forward part of the mouth, you should be able to remove the hook without trouble using forceps or needle-nose pliers. If the hook is in the gill filaments, you may need to be more delicate to ensure the fish has no gill damage. If the hook is in the throat, you may need to remove the point and the barb to reduce the potential risk of damaging the throat during removal.



PHOTO BY ROB MATSUURA



PHOTO BY MATT BROWN

If the hook is not visible or can't be removed within several seconds, you should cut the line as close to the hook as possible and even remove the eye of the hook if it's accessible.

Once the hook has been removed, taking pictures or weighing the fish is a great way to memorialize your catch, but it should be done quickly. At that point, the fish can be released and allowed to recover naturally.

At any point, if you notice the fish is bleeding from the gills, your best practice is to get it back into the water immediately. The way water flows through the gills creates a backward current that will stop the bleeding more quickly than anything you can do in your boat.

### ABOUT THOSE LIVEWELLS

If you're competing in a weigh-in-style event, you will of course need to livewell fish for transport. The livewell systems on most boats can be extremely safe environments if you keep water moving through the system. It's best practice to know the water temperature of your livewell and to keep it within 5 degrees of the water temperature you removed the fish from.

Water should be added to the livewell periodically to ensure that oxygen does not become depleted and that harmful gases are periodically flushed out. Your recirculation pumps should also run continually. If you're culling fish during the event, you should use a clasp-style cull ring that does not penetrate the mouth of the fish in any way. When you arrive at the weigh-in, you should minimize the time the fish are in the weigh-in bag, as this environment can cause stress and rapid loss of dissolved oxygen.

### FISH CARE FROM A TOURNAMENT PERSPECTIVE

Weigh-in is where most organizations start their fish care. MLF holds 200-plus events every season using a five-fish-limit weigh-in format in addition to the Bass Pro Tour's format, so we get to spend a lot of time perfecting our fish-care procedures.

At weigh-in, the key is to minimize the time a fish spends in a bag. The holding tanks leading up to the weigh-in stage should be equipped with cold water that has diffusers you can put into your bag to incorporate air movement. If there

isn't a diffuser, you can splash water into the bag to try to increase its dissolved oxygen content.

Immediately following the actual weighing of the fish, the bag should be refilled with water and transported to a live-release boat, where the fish are placed into larger tanks that have dissolved oxygen diffused into the water continuously. Our live-release crews monitor the pounds of fish going into each tank, the dissolved oxygen and water temperature to ensure that all fish can have an optimal environment to get them safely back into the fishery.

If any fish was caught in extremely deep water or is experiencing barotrauma, our live-release teams will remove gas from the swim bladder to alleviate that stress. As the weigh-in concludes, the live-release boats can then travel out to designated release points that provide the fish the ability to quickly recover from the tournament stress.

We try to diversify our release locations to minimize our impact on stockpiling fish in specific marinas.

### OUR PROMISE AS AN ORGANIZATION

Major League Fishing prides itself on setting a very high standard for fish care, including our live-release percentage at all MLF5 events and exclusively using the catch, weigh, immediate-release format on the Bass Pro Tour and in the MLF Cups. Over the coming years, we will continue to innovate new possibilities to monitor fish health, maximize their survival and provide opportunities for more catch, weigh, immediate-release tournaments. ■



PHOTO BY JODY WHITE



PHOTO BY JODY WHITE

**ANYWHERE IS POSSIBLE.**



**GENERAL TIRE**

[WWW.GENERALTIRE.COM](http://WWW.GENERALTIRE.COM)

**Grabber™ X3**  
MUD, DIRT & ROCK  
EXTREME TERRAIN



# WHAT TO WATCH IN THE COMING WEEKS

## TV BROADCASTS

### Sportsman Channel — Wednesdays 10 a.m.–Noon (ET)

- Oct. 20: Tackle Warehouse TITLE @ Mississippi River Presented by Mercury Day 3
- Oct. 27: Tackle Warehouse TITLE @ Mississippi River Presented by Mercury Day 4
- Nov. 3: Tackle Warehouse TITLE @ Mississippi River Presented by Mercury Day 5
- Nov. 10: Tackle Warehouse TITLE @ Mississippi River Presented by Mercury Day 6

### Outdoor Channel — Sundays 7–9 a.m. (ET)

- Oct. 17: Tackle Warehouse TITLE @ Mississippi River Presented by Mercury Day 2
- Oct. 24: Tackle Warehouse TITLE @ Mississippi River Presented by Mercury Day 3
- Oct. 31: Tackle Warehouse TITLE @ Mississippi River Presented by Mercury Day 4
- Nov. 7: Tackle Warehouse TITLE @ Mississippi River Presented by Mercury Day 5
- Nov. 14: Tackle Warehouse TITLE @ Mississippi River Presented by Mercury Day 6

### Discovery Channel — Saturdays 7–9 a.m. (ET)

- Oct. 16: B&W Trailer Hitches Stage Four @ Lake Chickamauga Presented by ATG x Wrangler Championship Round
- Oct. 23: General Tire Stage Five @ St. Lawrence River Presented by Berkley Knockout Round
- Oct. 30: General Tire Stage Five @ St. Lawrence River Presented by Berkley Championship Round
- Nov. 6: Toyota Stage Six @ Lake Champlain Presented by Googan Baits Championship Round
- Nov. 13: Carparts.com Stage Seven @ Lake St. Clair Presented by Covercraft Championship Round

FOLLOW  
MLF ON  
SOCIAL  
MEDIA



The broadcast schedules are for episode premieres. Most shows will re-air on Outdoor Channel and/or Sportsman Channel. Complete schedules are available online.

**WE ARE CHAMPIONS**

**WE ARE BASS FISHING™**

**MLF** MAJOR LEAGUE FISHING

**MAJOR LEAGUE FISHING CHAMPIONS CLUB**

**ONLY \$29<sup>99</sup>/mo. JOIN TODAY!**



# Followed by the best in the field



## CONGRATULATIONS

to our 2021  
**Tackle Warehouse  
Pro Circuit TITLE**  
qualifiers



what you fish matters



[www.baits.com](http://www.baits.com)

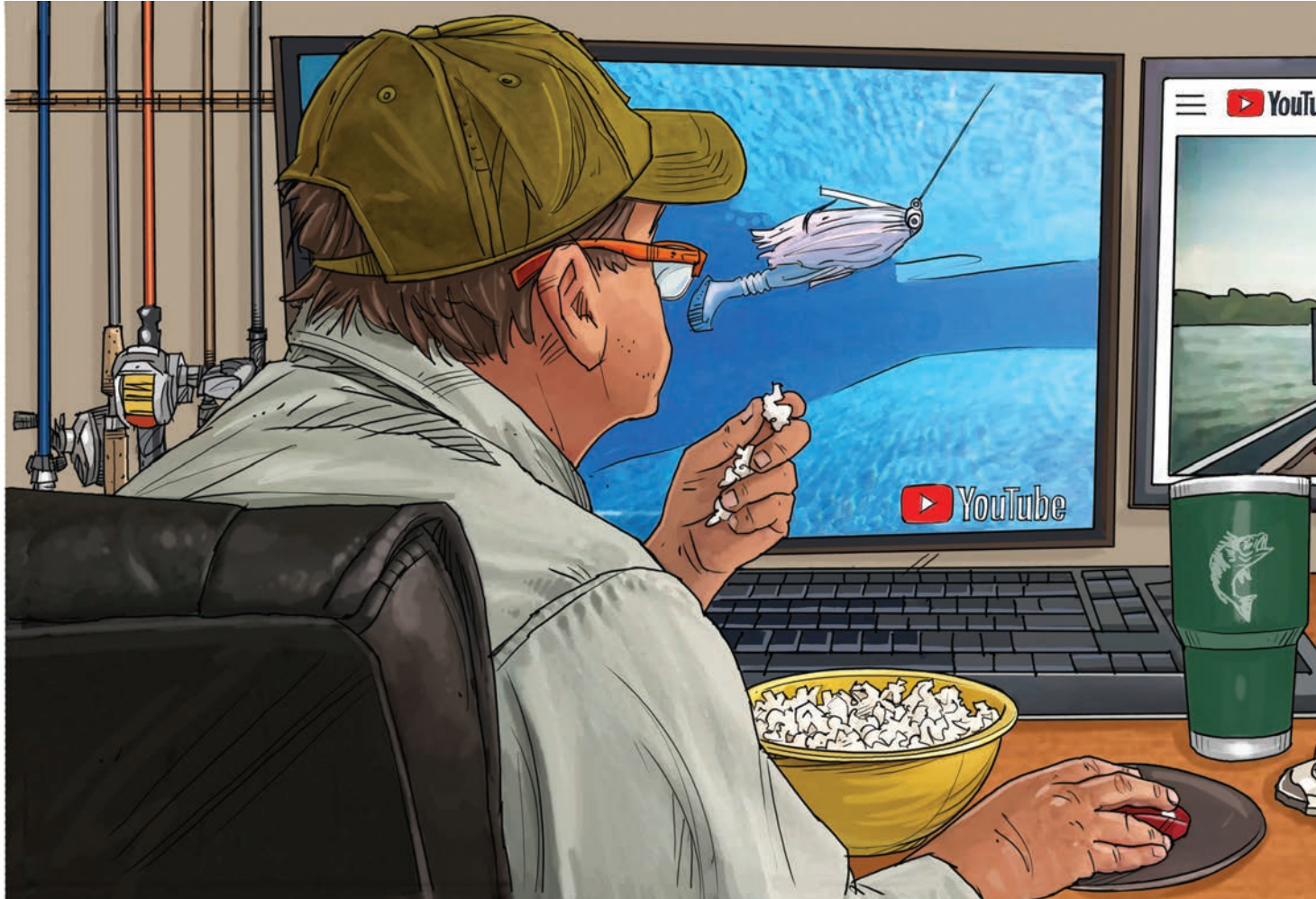

**ABOUT THE AUTHOR**

As a freelance writer and photographer, **Rob Newell** has been reporting on fishing tournaments for 20 years, finding the stories between fish and angler to be a stretched line of heroes, heartache, triumph, torture, inspiration and exasperation.

# YOU-TUBE

How bass pros are changing the game for you, the everyday angler

**I**'ve been watching the proliferation of bass fishing on YouTube for about a decade now. At first, I thought YouTube and professional bass fishing would never mix. It's a great source of entertainment, sure, but when it comes to credible information, it can be underwhelming. The fact is, anybody can be an "expert" at anything on YouTube. I can video myself folding a piece of paper in half and title it "Origami Secrets" and begin counting my views.

Given that, much of the early bass fishing content on YouTube consisted of casual anglers videoing their recreational fishing trips for fun. There was more emphasis on the follies that come with fishing rather than the catching. There

were a handful of anglers producing constructive content in terms of teaching fishing, but those topics often got lost in YouTube's sea of rambling vlogs, unboxings and red arrows pointing to captions like "see what happens next."

On the flipside, the primary audience consuming fishing content was looking for videos without an agenda. As a result, the just-fishing-for-fun vibe on the platform caught fire. Since professional fishing for big money is a more serious business, I couldn't see pro anglers and YouTube mingling.

Professional anglers dabbled in the YouTube game early on, but patched-up pros pushing product were not exactly the preferred YouTube "influencers" at the time. Also, pros' content



ILLUSTRATION BY JOE MAHLER

was subject to being monitored by sponsors. The camera catching a glimpse of a competing brand's lure somewhere in the boat could provoke a phone call from corporate. Then there were the reservations about giving out true fishing secrets on such a public platform. Finally, full-time tournament pros simply did not have the time to film, edit, render and post videos to keep pace with those who were full-time influencers. In the beginning, there wasn't exactly a whole lot of incentive for pros to get on YouTube and post their trade secrets for all to see.

Over the last few years, however, the tide has shifted substantially. Now more professional anglers than ever have cranked up their video game, raising the value of bass fishing information on YouTube to a higher level. I've been stunned at how many close-to-the-vest secrets of bass fishing have been disclosed on the platform in the last few years – by the pros themselves, no less.

The reasons for this shift towards stronger fishing content are numerous, starting with the COVID-19 pandemic. Half a year off in 2020 gave pros time to devise how they wanted to hone and present their content. Older pros, some with the help of their teenage kids, were able to get a better grasp of how to play the YouTube game. With that, bass professionals are now

more aware that the audience is not into a 20-minute infomercial – there must be some real substance in the content for it to get traction.

Also, point-of-view cameras have become a way of life for most pros. On-board cams are now as much a part of the game as rods and reels. In fact, some tournament circuits require these cameras to be present during competition in the event of a rules dispute. If you're going to run a camera all day during a tournament, you might as well turn those fish catches into content. While some pros have outsourced the filming and editing to those who are savvier in the technical end of the game, the angler is still generally very hands-on in the process and the finished product.

Above all, I think the biggest reason for this wave of better production value is that pros are extremely competitive by nature; once the race to better content got started, it was game on. As it turns out, many pros make pretty darn good producers of fishing videos when given the freedom to narrate their own tournament experience or break down a technique. This evolution is quite a boon to viewers. Some of MLF's top players in the tournament game are the ones posting their own content on YouTube. From tutorials to their own tournament coverage, the content is loaded with bass catching secrets that have been kept mum for years.

Top MLF performers like Jacob Wheeler, Edwin Evers, Ott DeFoe, Mark Daniels Jr., Justin Lucas, Skeet Reese, Dustin Connell and David Dudley are just a few of the various names posting tournament coverage from their own boats after an event is over. This is where some of the best information is revealed in terms of equipment, lures, presentations, colors, pace, strategy, adjustments, weather windows, attacking cover, boat position, etc. They don't always verbalize or point out the more subtle secrets, but I can assure you they are there for the viewing. In many cases, it's raw footage during a national-level tournament: You see the baits, the casts and where the bites come from relative to the cover, while listening to the pro think through the process – it doesn't get any better than that.

For example: Lucas' tournament videos are very candid in terms of his equipment and his ups and downs during each tournament day. DeFoe's coverage of his Bass Pro Tour wins at Sam Rayburn and the Harris Chain both are chock-full of lessons, especially the importance of casting angles and lure sequences. Wheeler's videos are money because he's always thinking out loud with his strategy. Why is he so good? Listen to the way he thinks all day while in competition.

It's not just the young guys, either; I like the way Evers and Reese break down their footage as they review the tournament, personally narrating their successes – and failures – during the event. The veteran pros are their own harshest critics, so listening to them "review tape" of their performance is excellent learning material.

Evers' *Project E* is a great example of how far pro fishing has come on YouTube in recent years. He's always been pretty tight-lipped about his trade secrets, but lately he's pulled back the curtain on some of his best tricks of the trade with his tutorials and tournament recaps. Professional bass fishing content on YouTube is strong – and far better than origami secrets. ■



# TOW & STOW®

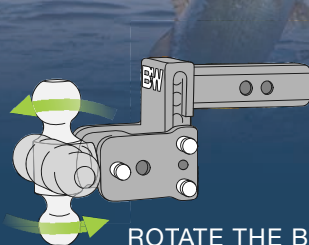

ROTATE THE BALL

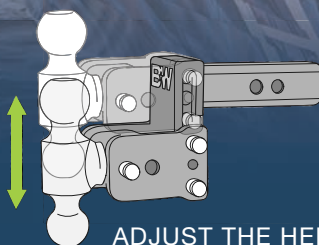

ADJUST THE HEIGHT

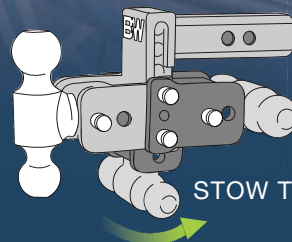

STOW THE HITCH

[bwtrailerhitches.com](http://bwtrailerhitches.com)



Shhhhh. No wake zone.



Protect your baby (and their toys) with coverage for fishing gear and personal property too.

1-800-PROGRESSIVE / PROGRESSIVE.COM

**PROGRESSIVE**

Progressive Casualty Insurance Co. & affiliates. Additional charge may apply. Prices vary based on how you buy.



## SURVIVING THE PRESSURE COOKER

How Michael Neal and Skeet Reese fend off the stress of fierce competition



### ABOUT THE AUTHOR

For more than 20 years, **Joe Balog** has made his living in the fishing industry on and off the water. A successful tournament angler from the Great Lakes region, Balog now lives in Florida, where he continues to work in product design, marketing and outdoor media when he's not chasing trophy largemouth.

**S**eventeen points. In the end, that was Michael Neal's margin of victory over Skeet Reese for the Tackle Warehouse Pro Circuit Angler of the Year title.

Looking back at the season, it's hard to fathom how anyone could have beaten Reese in a season that included four Top-10 fishes in six events for the seasoned vet, including a win at the opener. In the season finale on the St. Lawrence River, Reese again turned up the heat with a massive Day 3 stringer in an attempt to overtake Neal in the points race. The latter answered with an 11th-place showing of his own to seal the deal.

I often wonder how they do it. With so much on the line and such relentless competition, how do certain anglers never seem to falter? This season's AOY race offers insight.

Neal had been close before. On a number of occasions, he finished near the top of the AOY standings, yet the title evaded him.

"It seemed like I always had a bad event that kept me from winning," he says.

The 2021 season would be different, both in terms of strategy and outcome. Neal fished to win at each event and never let off the gas.

"I knew it was going to be tight," Neal says of coming into the last stop of the Pro Circuit season with a slim lead over Reese. "I fished there to win, just like every other event. The safe thing may have been to fish for largemouths, but I never did. I couldn't."

With a legend like Reese breathing down his neck, Neal made the right move. Reese originally planned to miss the St. Lawrence event, scheduled on top of a family vacation to Europe two years in the making. Instead, he cut short his visit abroad and came home to challenge for AOY. After a 25-year career, Reese still considers that award to be a defining title. But, like Neal, his approach all season was focused.

"I'm fishing for me," Reese says. "I've accomplished a lot in my career, and I've learned that one tournament does not define me."

In the past, Reese has been vocal about his pursuit of perfection through attitude. There's only so much an angler can control.

"I focus on the process of each tournament - not the outcome," he adds. "I can only control the process."

Part of the process is the use of lures and techniques that fit his style, regardless of tournament location. "All strengths and no fear," as Reese puts it. He enters each event with no preconceived notions or forced patterns. Everything is wide open from the opening bell.

Neal concurs, to some degree.

"I'm going to fish the way I want to, so that's all the tackle I keep in my boat," he explains. "I try to fish on instinct."

Neal insists on a principle he terms "no no-confidence baits." In other words, there's no place in his repertoire for unproven lures or unfamiliar methods.

Of interest, however, is Neal's removal from fishing when he's not on the tournament trail.

"When I'm home, I don't fish; I try not to even think about fishing," he admits.

We've heard this before from other pros, most notably Andy Morgan. Neal feels his routine puts him in a higher gear once he's on location and helps keep his strategy manageable.

"Too much prep equals too much in my head," he admits.

It's true. Attitude can be everything. Just ask Reese.

"Life, in general, can be a mindset," he says. "It's easy to get caught up in the negativity. I realized it doesn't have to be that way. Just because I lost a fish, let's say, doesn't mean my career is over. The key is to get back to focus; to regain control."

Neal seems to always be in control from the start.

"I'm pretty laid back," he says. "I hardly ever get frustrated on the water, but I'm a lot more open now than ever, in terms of fishing."



PHOTO BY JOSH GASSMANN

Undoubtedly, Neal's open attitude has helped. Case in point: At the season's final event, Neal had discovered a rock pile pattern that kept him in contention. In between spots, however, he found a grass line that held enough fish for a strong finish. In the past, Neal insists he never would have been open to trying new things with so much on the line.

Staying flexible is the key to dissecting each new fishery. Just like Reese, Neal is immediately focused once practice begins. He moves quickly.

"I don't need to be flipping. I need to be winding," Neal says. "Everywhere we go, there's an area where I can fish that way - even in Florida."

Of particular interest, both Neal and Reese are quick to credit their no-holds-barred fishing approach to competition on the Bass Pro Tour.



PHOTO BY COBI PELLERITO

"The BPT forces you to practice on the fly, constantly expanding," Neal says. "There are no slack times."

"You have to be always catching fish - always," Reese says. "I've learned that if you keep catching fish of any size, quality fish will come with them."

Even in other formats, like the five-fish-limit format on the Pro Circuit, Reese's plan is to keep on catching.

As the sport progresses, so too does the level of competition. Angler of the Year races get tighter, requiring nearly flawless performances at each stop to be in contention. Top pros like Reese and Neal, who compete on multiple circuits, see venue changes weekly. They have no choice but to fly by the seat of their pants.

This open approach allows competitors to fish without history, running patterns as they develop. We're seeing now how beneficial this approach can be to competitors who fearlessly stick to the plan. In the long run, we'd all surely benefit from the same practice. ■



# PHOENIX

BOATS

## 721 ProXP

with the Mercury 250  
Pro XS Four Stroke

**\$64,495\***

**INCLUDES** all standard features of the 721 Pro XP  
along with your **CHOICE** of custom **COLORS**

Plus: MINN KOTA ULTREX 112 / TWO 8' BLACK POWER-POLE® BLADES  
CUSTOM COVER / PADDED DECK / TWO HUMMINBIRD G4N HELIX 9'S  
4X10 CHARGER / MERCURY PROP / CHANNEL FRAME TRAILER



## 921 Elite

with the Mercury 250  
Pro XS Four Stroke

**\$75,495\***

**INCLUDES** all standard features of the 921 Elite/920 Elite  
along with your **CHOICE** of custom **COLORS**

Plus: MINN KOTA ULTREX 112 / TWO 8' BLACK POWER-POLE® BLADES  
CUSTOM COVER / PADDED DECK / TWO HUMMINBIRD G4N HELIX 12'S  
4X10 CHARGER / MERCURY PROP  
CUSTOM WHEELS / CHANNEL FRAME TRAILER



## 920 Elite

with the Mercury 250  
Pro XS Four Stroke

**\$73,995\***

\*\* Nationally-advertised price, does not include dealer prep, batteries, freight, taxes, registration and licenses and is for 2021 model year. Phoenix Boats reserves the right to make changes in products and pricing without prior notice. Dealer determines final price. Dual color deck, polyflake hull and gelcoat pinstripe upgrade fees will apply.



# 21 PHX

with the Mercury 250 Pro XS Four Stroke **\$76,995\***



**INCLUDES** all standard features of the 21 PHX/20 PHX along with your **CHOICE** of custom **COLORS**

Plus: **MINN KOTA ULTREX 112 / TWO 8' BLACK POWER-POLE® BLADES**  
**CUSTOM COVER / PADDED DECK / TWO HUMMINBIRD G4N HELIX 12'S**  
**4X10 CHARGER / MERCURY PROP**  
**CUSTOM WHEELS / CHANNEL FRAME TRAILER**

# 20 PHX

with the Mercury 250 Pro XS Four Stroke **\$75,495\***

Find your local Phoenix Dealer at  
[phoenixbassboats.com](http://phoenixbassboats.com)

**#builtbyanglersforanglers**

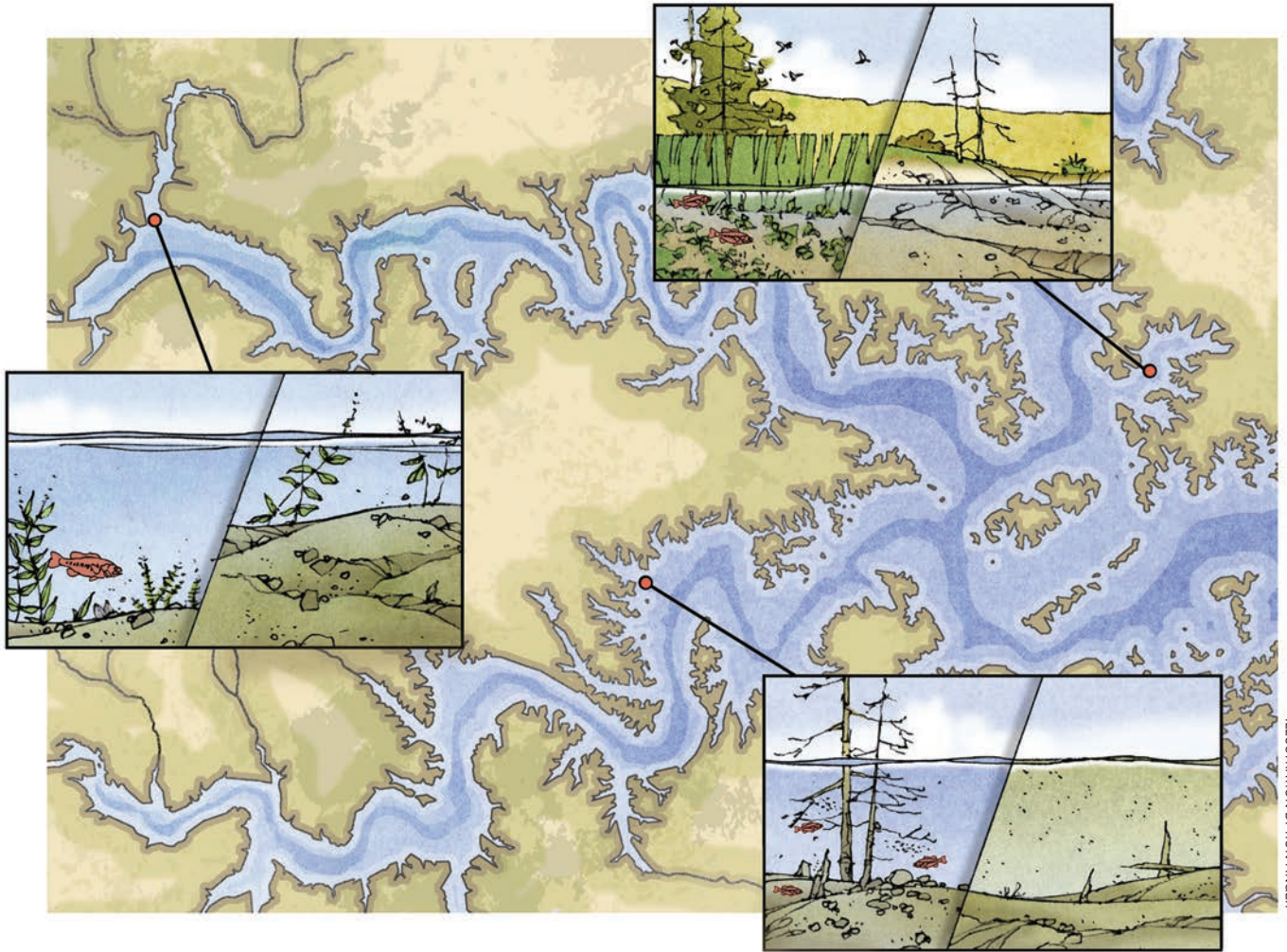

ILLUSTRATION BY RON FINGER



**ABOUT THE AUTHOR**

**TJ Maglio** is a tournament angler and outdoor writer based in Minnesota. He has a degree in wildlife ecology from the University of Wisconsin-Madison and has also worked professionally as a wildlife biologist and environmental consultant.

# THE EFFECTS OF AGING RESERVOIRS

We can't do much about it, but understanding the process is a good start

**I**n 1997, an environmental journal estimated that there are over 800,000 man-made dams in the world. Whether built for flood control, irrigation, water storage or any other purpose, all those dams have a reservoir behind them. If said reservoir is in the U.S. (and an increasing number of other countries) it probably has bass swimming in it.

Reservoirs provide innumerable economic and recreational benefits, and it's hard to think of them as anything other than timeless. Like all things, though, reservoirs have to fight the effects of aging.

The first thing you may think about the concept of "reservoir aging" is in terms of the actual dam structure and the kinds of maintenance you

may need to ensure it lasts, lest we see another dam failure like the one that almost occurred on California's Lake Oroville in 2017. Although the wear and tear on those engineered bits is important to consider, that part is for the politicians and engineers to work out. We want to look at the concept through the eyes of a bass angler – and how reservoir aging can impact a fishery's bass population.

## DEPOSITION

When streams, creeks or rivers swollen with spring rains merge with the deeper waters of a reservoir, their current slows, and suspended particles (sand, silt, organic matter) slowly fall to the bottom. This annual process "deposits" new

material on the bottom of the fishery and is a major component in reservoir aging. It can impact a fishery in several ways, including a reduction in shallow spawning areas.

Bass often prefer to spawn in the backs of pockets, and over time, pockets can silt in. This makes them less suitable for spawning, which at a large scale can impact bass populations through loss of spawning habitat.

Many reservoirs are also designed for water storage, and deposition reduces water storage capacity. This has municipal impacts, particularly combined with widespread drought like is happening in much of the West right now. Low water also limits angling access, as many ramps are only usable at certain water levels.

Finally, on reservoirs used for major transport, deposition can impact shipping and navigation. Similarly, it can be harder to get your boat into prime fishing areas due to siltation. Many marinas and canals often need to be dredged to remove new layers of silt, which is costly to stakeholders.

## EROSION

Wave action, rising and falling water levels over time and lack of a wetland buffer can cause some significant erosion problems in reservoirs as they age. This has impacts throughout the system, including habitat homogenization and barren littoral habitats.

When shoreline erosion gets bad enough, it reduces riparian wetlands, prevents or negates growth of aquatic vegetation and causes bank sloughing or caving. Over time, this causes long stretches of bank to become featureless. Older reservoirs with erosion problems have much less unique shallow habitat

than younger and less-eroded reservoirs. Lack of unique shoreline habitat creates a less habitable place to be if you're a fish, creating "barren" areas up shallow where very few fish spend any time.

## HABITAT LOSS

Bass are crafty and adaptable, which is why they thrive in such diverse places. As reservoirs age, however, they become much less diverse, and deposition and erosion lead to poorer-quality bass habitat. Specific examples include loss of woody cover, siltation in hard-bottom areas and decreases in water clarity.

Wood (brush, standing timber, laydowns or stumps) is classic bass habitat. Over time, wood degrades and standing timber gets knocked down by wave and ice action. This naturally leaves bass with fewer places to hide.

Rock piles, gravel patches, shell beds and even stumps are also prime bass country. Siltation covers them up over time, too, turning spots that were once loaded with bass into featureless ghost towns.

Erosion and lack of shoreline vegetation can cause turbulent water, and high nutrient runoff can cause algae blooms in older reservoirs. Those can also impact a fishery from a productivity perspective and change the techniques and presentations that are most effective for chasing bass.

Unfortunately, understanding how reservoirs change through the years doesn't change the fact that many of the effects are irreversible. As bass anglers, we simply need to find ways to understand and adjust to the everchanging waters we fish on a regular basis. ■

## THE "NEW RESERVOIR EFFECT"

In 2008, the Toyota Series Southwestern Division fished a four-day event on Falcon Lake in southern Texas (the reservoir spans the border of Texas and Mexico). The result: four anglers topping the century mark, including a 110-pound, 2-ounce bag from winner Jeremy Guidry.

That tournament took place during a period when Falcon Lake was experiencing what fisheries biologists call the "new reservoir effect," and was just one of many record-shattering events on what was then probably the best bass fishing lake in the world.

Throughout the 1990s, Falcon Lake (and southern Texas in general) went through an extended period of intense drought that led to low water for years at a time. During that time of low water, dense vegetation grew along the shoreline. In 2004 the rains came, and the lake started to rise, inundating all that brush.

By 2008, the lake was full and nutrients from all that flooded brush combined with endless shallow cover and created an explosion of life that led to several years of epic fishing.

While not very common, the new reservoir effect happens from time to time as nature experiences major swings within its regular cycles. We can't do much about the negative effects of reservoir aging on our favorite fisheries, but we can still take advantage of the positive changes in other reservoirs throughout the country.

Jeremy Guidry



PHOTO BY BRETT CARLSON



# POWERBAIT® MAXSCENT

YOUR FISH. OUR SCIENCE.

POWERBAIT MAXSCENT  
MEATY CHUNK  
AVAILABLE IN 5 COLORS  
+ 2 SIZES



NATURAL SCENT DISPERSION

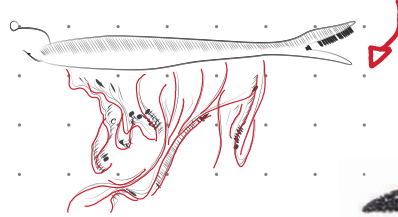

POWERBAIT MAXSCENT  
FLAT WORM  
AVAILABLE IN 10 COLORS

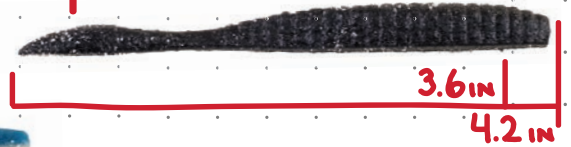

POWERBAIT MAXSCENT THE GENERAL  
3 SIZES + 17 COLORS AVAILABLE



POWERBAIT MAXSCENT  
FLATNOSE MINNOW  
AVAILABLE IN  
10 COLORS

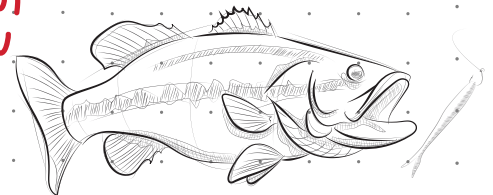

SCIENTIFICALLY OPTIMIZED  
FOR LARGEMOUTH AND  
SMALLMOUTH ALIKE



NATURALLY AND QUICKLY  
DISPERSES SCENT INTO WATER  
UNLIKE ANY OTHER BAIT CREATED

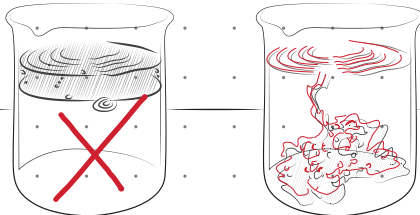

POWERBAIT MAXSCENT  
CREATURE HAWG  
AVAILABLE IN 10 COLORS

## SMELLING IS BELIEVING.

Plenty of soft baits look appealing to fish. But fish don't use vision alone when feeding. In fact, based on decades of scientific research, the team at Berkley has identified that scent and taste play even more of a role in convincing a fish to bite, and hold onto, a bait than any other sense.

Berkley PowerBait® MaxScent soft baits are the only bass baits ever created that are able to truly deliver a scent that is not only appealing, but able to quickly disperse into the water column to actually attract fish. Other baits and attractants may smell above the water but they are proven to be either ineffective or even offensive to fish when put into use.

Now available in a myriad of shapes, sizes and colors, Berkley MaxScent has been designed and tested in the lab and proven on the water to deliver bites other baits won't.

Berkley MaxScent.

We've done the science. Now you catch the fish.



[www.berkley-fishing.com](http://www.berkley-fishing.com)

©2021 Pure Fishing, Inc.

# HUK



TO CATCH MORE FISH REQUIRES  
SKILL, LUCK, TENACITY AND - ONE COULD ARGUE -  
**EXACTLY THE RIGHT SHIRT.**

**ICON X. THE MOST BREATHABLE SHIRT. EVER.**

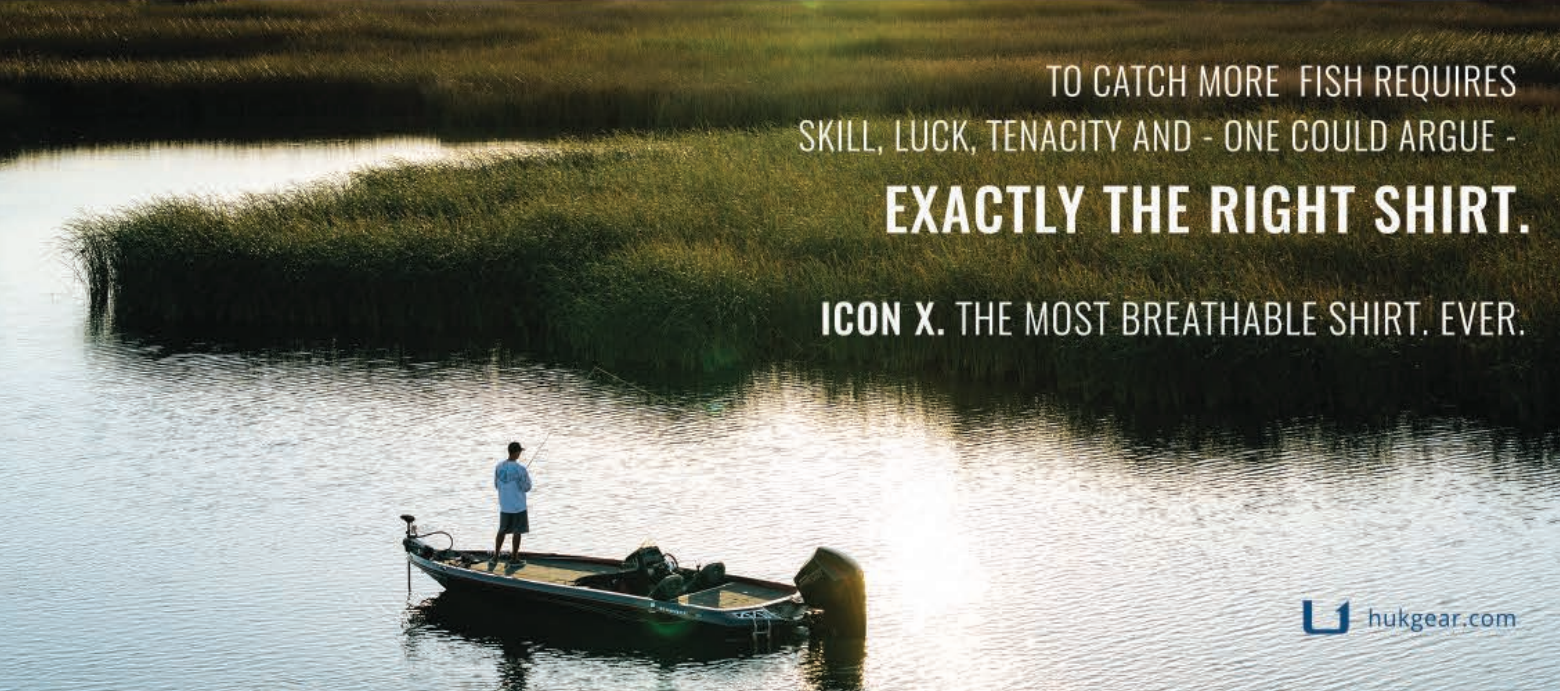



## BAITFISH BONANZA

No matter where you are in the country, fall is the season to chase bass chasing bait



### ABOUT THE AUTHORS

**Matt Allen and Tim Little** are well-known big-bass experts who own Tactical Bassin, a website and social media channels dedicated to educating the public about bass fishing.



**C**ooler temperatures are creeping across the country and the fish are getting more aggressive along with it. This time of year, you don't need to know the water temperature at your local lake to know that cooler nighttime temperatures trigger a feeding response in bass.

It's a phenomenon that takes place in every lake across the country: Before winter sets in, bass chase baitfish. They spend the fall months feeding – and feeding heavily – in preparation for winter.

How you apply that information depends on the size of baitfish in your local fishery. Do you have smelt, small shad (like threadfin) or other small baitfish? Your plan of attack should differ from the angler whose fish are corralling alewives, gizzard shad, panfish or trout. Regardless of the size of the baitfish, one universal truth remains: Bass are going to be eating them. It's time to take advantage.

### FISH IN A (VERY LARGE) BARREL

In most lakes, two different scenarios play out simultaneously this time of year. Some baitfish will move shallow and find themselves corralled into the backs of pockets, coves and creeks. They'll use docks, brush, grass and other shallow cover in an attempt to evade bass. Other baitfish will remain deep, but will ultimately end up in the same predicament – pinned against bluffs, channel bends and in the back of deep coves.

The scenario I'm describing is one of the most amazing opportunities you'll ever have as an angler.

Bass that chase these baitfish in the shallows won't be hard to find. You don't need the best electronics or a fast boat. You can idle along the coves and pockets in your boat or drive the lake shore in your car. It won't take long to see bass exploding out of the water, pinning baitfish to the shoreline.

### THE TACTICS IN PLAY

Right now, bass are moving around baitfish in very predictable ways. Some bass will be swimming around the perimeter of the school, keeping them bunched together. The rest of the bass will be lurking below, waiting to shoot up through the school for a quick, sizeable meal.

The key to catching any of these fish is to stand out from the crowd. There may be 10,000 baitfish pinned in the back of a single cove, so how do you get the bass to notice your bait? Our recommendation is to focus on baits that make a ruckus.

First, opt for a topwater. No matter the size of the baitfish, start with an aggressive walking bait like an Evergreen Shower Blows or a River2Sea Rover. The more commotion your offering makes and the harder the bait darts from side to side, the more likely you are to distract a bass from the thousands

of other potential meals. If the fish are swirling through the baitfish or slashing at your bait without committing, it's time for Plan B.

Your next move should be a soft jerkbait like a Zoom Super Fluke – a bait that can be snapped and popped aggressively and worked both above and below the surface. Schooling bass can't resist this erratic action. If the activity cools off or the bass disappear, that's when we like to turn to subsurface presentations like an underspin, a squarebill crankbait or a glide bait. Depending on the depth of water, the size of the baitfish, and how much cover they're around, we adapt each presentation for best results.

## TOOLS OF THE TRADE

We always pair an underspin with a swimbait like a Keitech Swing Impact FAT or a Storm Largo Shad. The bait should be sized appropriately to match the baitfish (our most common sizes are generally between 3 and 5 inches). Rigging these swimbaits depends on how much cover you're fishing around. If the baitfish are in grass, brush or other snaggy cover, we go with an Owner Flashy Swimmer, which allows our bait to be fished over, around and through any debris. In open water, we rely on a Blade Runner Spintrix. The Spintrix, in our



experience, often gets the biggest bass because we fish it slower and closer to bottom where the biggest bass in the school typically lurk.

A squarebill is a search tool. You can use it with an aggressive stop-and-go retrieve and quickly probe the edges of a baitfish ball, especially if it's moving down the shoreline attempting to evade hungry bass. The key to success with a crankbait is matching the bait to the depth of water you're fishing. If the baitfish are right on shore, we turn to a Spro Baby Fat John 50. If the water isn't quite so shallow, a 1.5- or 2.5-size squarebill will suffice.

The final tool in the shallow arsenal is the glide bait. While this presentation could be a whole column itself, for this situation, we keep it very simple: If the bass are chasing larger baitfish, the glide bait is king.

In the world of glides, you still want to focus on the smaller end of the spectrum. Smaller, more aggressive glide baits are what we call "cover glides." These baits

swim with an S-motion in the water but can be popped and worked aggressively around visible cover to elicit aggressive strikes. The two baits that immediately come to mind for this presentation are the River2Sea S-Waver 168 and the Storm Arashi Glide. Match the color of your glide to the baitfish you're imitating and spend your time swimming it around the outer edges of baitfish schools.

## AN EVEN BIGGER BARREL

When targeting bass chasing schools of baitfish in deep water, the overall concept is exactly the same, but the baits and equipment needed to reach those bass ambushing bait in 15 to 50-plus feet of water are completely different.

First, electronics are going to make a huge difference. We rely heavily on our electronics in the fall as we side-image creek channels, cove mouths and bluff walls in search of schooling bait. Side imaging cuts your search time dramatically and has been a life saver for us in recent years. (If electronics aren't in play for you, the best bet is to watch the birds: Keep an eye out for loons and other deep-diving birds that rely on these same deep-water schools for food.)

Once you've found the bait, it's just a matter of changing up your presentation. For us, topwater baits are replaced with spoons. You can catch these fish on both jiggging spoons and flutter spoons, depending on depth. In less than 20 feet of water, the Nichols Flutter Spoon does a great job imitating a dying bait fish and often gets a ton of bites. At deeper depths, the jigging spoon is key. We rely on the Blade Runner Duh Spoon (1 3/4 ounce) to get down quickly. This spoon has a unique shape that still has a great flutter on the fall, unlike many traditional narrow-bodied spoons.



PHOTOS BY BRANDON ROWAN



River2Sea S-Waver



Nichols Flutter Spoon

Blade Runner Spoon



Blade Runner Spintrix with Keitech Swing Impact FAT



Underspin with Storm Largo Shad

In depths of less than 20 feet, a soft jerkbait can be replaced by a deep-diving hard jerkbait. A Megabass Ito Vision 110+2 can probe the depths and trigger a feed response, even in a school that has momentarily calmed down. The key with the jerkbait is getting down deep and suspending in place. If your bait is rising on the pause, you'll never get the depth you need to consistently fish for these deeper bass.

Our underspin selection remains largely unchanged in deep water: a Blade Runner Spintrix in 1/2 or 3/4 ounce to take our 4- to 5-inch swimbaits to the bottom. A steady, slow roll along the bottom below the baitfish is the best presentation.

Our final move when targeting deep-water schools is a deep-diving crankbait, which has been a killer in recent years with the advent of "speed cranking." Depth of the baitfish matters because there are limits to how deep you can get your crankbait, but if they're in less than 25 feet, speed cranking is the silver bullet. In 2019, we released the Tactical DD 75 crankbait in collaboration with River2Sea, a bait specifically designed for speed cranking in fall and winter. Other great options for this presentation are the Megabass Deep-X 300 and Deep Six.

As the name suggests, the key to this presentation is speed. Forget that 5:1

reel you've always used for cranking and turn instead to 7:1 or 8:1 gear ratio reels. Pair your bait with the lightest line you're comfortable with to get maximum depth and begin burning that reel handle directly through the middle of the baitfish schools. Once you've reached maximum depth, stop the bait, pause for just a fraction of a second and burn again. This stop-and-go retrieve draws the most violent strikes we've ever seen from bass, and best of all, bottom contact isn't necessary. You can use this method to catch fish out from under the school or suspending under the baitfish in open water alike.

Regardless of your preferred methods, get out of your comfort zone this fall. Baitfish often roam open water before bass corral them, so don't get caught fishing your same old haunts. The schooling phenomena can happen anywhere on the lake at any time of day, so keep your eyes peeled and a rod in your hands. This is the time of year to cover water, explore new areas and have fun doing it. Winter will be here before you know it. ■



TOYOTA



Official Vehicle

# A POWERFUL MONEY MAKER.



*Mark Daniels Jr.*  
MLF Professional Angler



TOYOTA

## BONUS BUCKS

**TOYOTA: THE TRUCK THAT PAYS MARK TO MAKE MOVES.** Major League Fishing BPT Pro Mark Daniels Jr. is taking the fishing world by storm. Since his pro debut in 2013, he has pulled in thousands in extra cash in his Tundra. You too can sign up for Toyota Bonus Bucks and roll like Mark for the opportunity to get paid for towing with a Toyota. Learn more and register for yourself at [toyotafishing.com](http://toyotafishing.com)

Vehicle shown is a special project car, modified with non-genuine Toyota parts and accessories. Modifications with these non-genuine parts or accessories will void the factory warranty, may negatively impact vehicle performance and safety, and may not be street legal. Before towing, confirm your vehicle and trailer are compatible, hooked up, loaded properly and that you have any necessary additional equipment. Do not exceed any Weight Ratings and follow all instructions in your Owner's Manual. The maximum you can tow depends on base curb weight plus the total weight of any cargo, occupants, and added vehicle equipment. "Added vehicle equipment" includes additional standard / optional equipment and accessories added by the manufacturer, dealers, and / or vehicle owners. The only way to be certain of your vehicle's curb weight is to weigh you vehicle without passengers or cargo. Calculated with new SAE J2807 method. To qualify for contingency payment, you must be a registered participant in the Toyota Bonus Bucks Program and place within the top 50 percent of the total field in qualifying tournaments. Only specific Toyota models (For the 2021 Bonus Bucks Program: 2017 or newer) are eligible and must be registered in your name individually or jointly. For complete rules and official registration form, please visit [Toyotafishing.com](http://Toyotafishing.com). \*Assembled in Texas with U.S. and globally sourced parts. ©2021 Toyota Motor Sales, U.S.A. Inc.



MADE IN AMERICA  
TOYOTA

\*Assembled in Texas with U.S. and globally sourced parts.

# UNSTOPPABLE AOY

JACOB WHEELER WAS  
AN OVERPOWERING  
FORCE IN 2021

By Joel Shangle

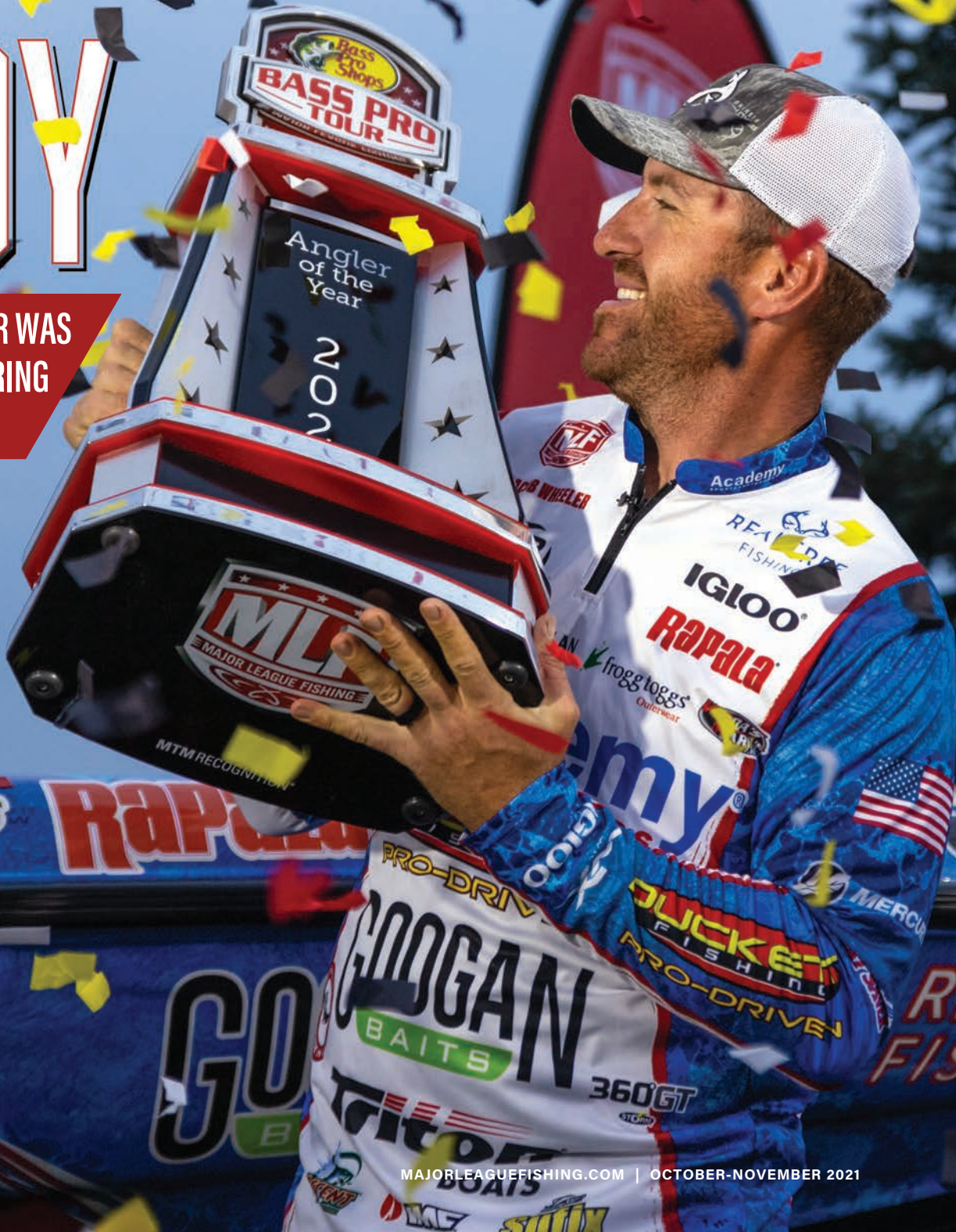



ou've heard the old saying about the overwhelming force versus the immovable object? Officially known as the "unstoppable force paradox," it sparks an age-old debate about

which is mightier: a force with unstoppable momentum or an object with unyielding tenacity.

It's the spear versus the shield. When one strikes the other, which will break?

Jacob Wheeler was the spear in 2021. The Tennessee pro came into the season riding the momentum of several years of excellence, in pursuit of his first Angler of the Year trophy. The anglers of the Bass Pro Tour were the shield in 2021, bracing for impact.

The unstoppable force won.

## DEFINING EXCELLENCE THROUGH OTHERS' EYES

You have to delve into the minds of Jacob Wheeler's competition to appreciate just how much of a wrecking ball he was during the nine-event Bass Pro Tour schedule.

Wheeler entered the 2021 campaign on the heels of a pandemic-shortened 2020 season in which he collected seven Top 10s in the 10 events he fished and racked up three wins (one Bass Pro Tour, one Pro Circuit Super Tournament, one Toyota Series). He entered the new season with a two-year grip on the No. 1 spot in the Bassang World Rankings and the status of automatic, perennial Angler of the Year threat thanks to a body of work that had grown increasingly impressive over the previous 10 years.

So when Wheeler's season began at REDCREST 2021 at Lake Eufaula in late February, it came as little surprise when he finished third. But that third-place finish was only the beginning of a season that will go down as one of the best in the sport's history.

PHOTO BY JOEL SHANKLE

**“NO MATTER WHAT,  
THOUGH, YOU HAVE  
TO PLAY TO WIN.  
I DON’T KNOW ANY  
OTHER WAY TO DO IT.”**

Wheeler regularly got his hands on a larger grade of largemouth during Stage Two on Lake Travis (top) which translated into the Tennessee pro getting his hands on Bass Pro Tour trophy one of three for the year (bottom).



PHOTOS BY GARRICK DIXON

Wheeler followed up his REDCREST performance with a 12th-place finish at the BPT regular-season opener on Sam Rayburn and a third-place finish at Heavy Hitters in Raleigh, North Carolina, and by the time Stage Two on Lake Travis rolled around in late April, “Wheels” was already winning the war of mental attrition against his fellow competitors.

“Man, that guy is so good,” Jordan Lee said as Wheeler drove by Lee’s boat in the parking lot at the Mansfield Dam launch on Lake Travis. “He’s so much better than anybody else out here right now, it’s not even funny. I don’t know how in the world I ever beat him. I don’t know if I’ll ever beat him again.”

Lee was semi-joking, but that tongue-in-cheek assessment was a telling statement (and high praise) from the defending Bass Pro Tour Angler of the Year and two-time Bassmaster



Classic champion. The unstoppable force was already gaining momentum in the minds of the anglers he was fishing against. And as most sports fans know, momentum in any form of competition is everything.

Wheeler would go on to win that event on Lake Travis by a scant 1 ounce over Bobby Lane, homing in on a series of deep docks up the Colorado River that held noticeably bigger fish than the rest of the lake and catching just enough largemouth to hold off Lane’s final-hour charge.

“Man, that guy is hard to beat,” Lane said simply as he watched Wheeler accept the champion’s trophy.

Wheeler had an uncharacteristically poor event at Stage Three at Florida’s Harris Chain (he finished 51st) but then rebounded with a second-place finish at Lake

Chickamauga in early June, an event in which Kevin VanDam opened up a massive lead in the third period of the Championship Round only to witness Wheeler stack nearly 14 pounds of largemouth on SCORETRACKER® in just 11 minutes to throw a mighty scare into the sport's all-time leading money winner.

"Oh yeah, it gave me a little anxiety," VanDam said with a chuckle. "You know what (Chickamauga) is capable of producing, and you know that Wheeler spends more time on that fishery than probably anybody, and what he's capable of."

## FIRING ON ALL CYLINDERS (TIMES TWO)

Wheeler entered the final lap of the season at Stage Five on Lake Champlain trailing Ott DeFoe by 25 points and Brent Ehrler by seven in the AOY race. DeFoe was midway through an outstanding season of his own, coming off wins at Sam Rayburn and the Harris Chain; Ehrler had been the model of consistency throughout the season, and could lean on the experience of five Top 3 AOY finishes in his career.

None of that made a difference as Wheeler ran away with the final round on Lake Champlain by 29 pounds. He

then became the first back-to-back winner in Bass Pro Tour history two weeks later when he outpaced the rest of the championship-day field by 25 pounds on the St. Lawrence River. In doing so, Wheeler became the first angler to win three events in a single season and the only person in the league's three-year history to own five of its red-and-silver championship trophies.

"I've seen a lot of people get on incredible rolls over the years — guys like David Fritts and Denny Brauer back in the day, or even Edwin (Evers), Jordan (Lee) and Aaron (Martens)," VanDam said. "Guys will have out-of-this-world seasons; that's not unusual. But what's really impressive about what Jacob did this year is, not only did he win three times, but he was in contention to win every single tournament except the Harris Chain. Even in that event, he had one bad day where he lost a lot of fish or I bet he would've been in contention there, too."

"You really have to have the moon and stars line up to win one event, so to win three is pretty special. Unless you're one of the 80 guys competing, you truly can't appreciate what you go through day to day during a tournament dealing with all of the things that Mother Nature throws at you."

## WILLING TO SUFFER FOR SUCCESS

Wheeler's St. Lawrence win was a testament to his willingness to endure difficult — and downright uncomfortable — conditions in pursuit of the most obvious (to him) path to victory. While multiple anglers in the 80-man field made bone-jarring 60-mile runs upriver from the tournament takeoff site in Massena, New York to "the juice" near the mouth of Lake Ontario, Wheeler ran even further to locate fish that he knew would be unpressured.

He spent the entire tournament bobbing and jarring in a stretch of river near Wolfe Island that was completely unprotected from the wind, hunched on his knees over the gunwale with a flogger in one hand and rod in the other, waves crashing over the bow as he plinked away at bedding smallmouth.

"I couldn't always get the bait down, and it was hard just holding the flogger (while you're fishing)," Wheeler admitted. "It was definitely a physical and mental challenge. But at a certain point, you either deal with that and have a chance to win, or you don't."

Wheeler's tenacity on the St. Lawrence harkened back to one of his milestone early wins — 2014 BASSfest

It took three hard competition days on the St. Lawrence River, but Wheeler fished unpressured smallmouth to claim his second trophy.



PHOTO BY JOSH GASSMANN

The third Bass Pro Tour trophy of the season came on Lake Champlain, where Wheeler expanded on a pattern that he quietly developed throughout the week.



PHOTO BY PHOENIX MOORE

on Chickamauga — in which the then-23-year-old outpaced VanDam on the final day while suffering through a week-long illness that left him virtually unable to stand at the end of each competition day.

"This is not always a comfortable job," Wheeler said. "You play hurt sometimes. You play sick sometimes. No matter what, though, you have to play to win. I don't know any other way to do it."

## AN AOY-WORTHY FINISH

The 2021 season finale at Stage Seven set up as a classic shootout among Wheeler, DeFoe and Ehrler. Despite Wheeler's back-to-back wins, DeFoe still clung to a 12-point lead in the AOY race heading into the final six days on Lake St. Clair and Lake Erie, with Ehrler doggedly holding onto third place, well within striking distance.

The irresistible force went to work immediately: Wheeler piled up 102 pounds of smallmouth his first day on Lake St. Clair to DeFoe's 39 and Ehrler's 35. Wheeler finished the Qualifying Round with 131 pounds to DeFoe's 66, while Ehrler's season ended as he fell 3 pounds shy of the cut.

With his largemouth bite near the mouth of the Detroit River diminishing rapidly and Wheeler's undeniable momentum on Lake St. Clair making him an obvious favorite to advance to the final day, DeFoe woke up the morning of the Knockout Round with a Hail Mary move in mind: He ditched his

most productive waters and drove nearly 90 minutes south, to the southernmost fringes of competition boundaries on Erie, near Toledo, Ohio.

Translation: In an attempt to stave off the inevitability of Wheeler, DeFoe gambled his own hard-fought AOY campaign on water that he had never even seen before.

"This could be the worst spot in the whole area, or it could be really good," DeFoe said when he launched. "I didn't really have anything that I could win on out on the lake, so I figured I'd try something else. We'll see how it goes."

The Hail Mary fell short. Wheeler wrangled 67-1 to finish fifth in the Knockout Round while DeFoe ended up 30th with 27-11. Wheeler finished out the fifth day of the six-day tournament with confetti raining down on him as he accepted the 2021 Bass Pro Tour Angler of the Year trophy.

## WHY WHEELER IS A WINNER

Unlike the greats of tournament bass fishing who made their hay before the mid-1990s/early 2000s — the Fritts, Braeuers, Nixons and Davises of the sport — Jacob Wheeler has lived in the glow of Facebook, YouTube and live-streamed tournaments ever since he thundered onto the national bass-derby scene as the youngest angler to ever win both the BFL All-American (2011) and Forrest Wood Cup (2012).

He's achieved celebrity status among young anglers thanks to his willingness to break through the fourth

wall via YouTube, where he regularly welcomes viewers into his boat and racks up views in the millions with unprecedented access to his life as a top-tier bass pro.

His success in the MLF Cups in the years before the Bass Pro Tour — Wheeler has won more Cup competition rounds than anyone — made him a regular on linear television. His dominance in three years on the Bass Pro tour, where he's fished 14 Championship Rounds in three years, has translated to more live camera time than any other angler in the world (plus bonus time on Discovery and CBS-TV).

That camera time has revealed to the masses what most of Wheeler's fellow competitors have known for years: He's good at everything — finesse, power, electronics — he can do it all at an astoundingly high level. He's also one of the best in the history of the sport at quickly analyzing conditions and making adjustments on the fly.

"People fail to understand that Jacob is just an extraordinary human being, straight up," said Mark Daniels Jr., who has traveled with Wheeler since 2016. "I'm not saying that just because he's my boy; it's because I understand that I'm watching greatness happen right before my eyes. His ability to process information is just through the roof — it might take me an hour or more to run through a bay, but he'll have that whole place figured out in 30 minutes. It's unbelievable."

Wheeler's God-given abilities are backed up by a work ethic and single-minded dedication to catching bass that astound even the people who know him the best.

"He literally eats and sleeps bass fishing," Daniels said. "All the rest of us come home from a tournament and we'll go duck hunting or bike riding or something. We'll take a step back from it. Not Jacob. He never takes a step back. I guarantee that while I'm talking to you right now, if Jacob isn't hanging out with his family, he's researching something."

"He works twice as hard as anybody on tour. Me, Jacob, DC (Dustin Connell) and Adrian (Avena) will get back to the house after being on the water for 12 hours and Jacob will stay on his laptop until 2 a.m. looking at stuff. The dude never stops." ■

# THE BEST ON THE WATER

DESERVE THE BEST ON THEIR TRUCK



**Justin Lucas**  
A.R.E. Fishing Team Member

4 Career Wins  
42 Top 10s 51 Top 20s  
Angler of the Year 2018

**THE Z7**  
FROM A.R.E.



**CAPS, COVERS & ACCESSORIES FOR TODAY'S TRUCKS.**  
FOR MORE INFORMATION OR TO LOCATE YOUR  
NEAREST A.R.E. DEALER VISIT [4ARE.COM](http://4ARE.COM)



## TURBO FATTYZ™

**NEW** IDEAL FOR BUZZING ON THE SURFACE, SWIMMING, TEXAS & CAROLINA RIGGING  
6" BEEFY SWIMMING WORM DESIGNED IN CONJUNCTION WITH Z-MAN PRO MILES 'SONAR' BURGHOFF

**ELAZTECH**  
10X TOUGH ELAZTECH® CONSTRUCTION OFFERS EXTREME DURABILITY AND BUOYANCY

CURVED PADDLE TAIL DESIGN PRODUCES THUMPING ACTION AT ALL RETRIEVE SPEEDS AND EVEN ON THE FALL

SALT IMPREGNATED TO PROVIDE EXTRA BULK FOR LONG CASTS WHEN FISHED UNWEIGHTED

PRO-SELECTED COLOR PALETTE

**WATCH VIDEO**  
SCAN WITH PHONE CAMERA

[WWW.ZMANFISHING.COM](http://WWW.ZMANFISHING.COM)



# MICHAEL NEAL HAS ARRIVED

# AFTER YEARS OF CLOSE CALLS, THE 2021 TACKLE WAREHOUSE BOY IS FINALLY WHERE HE NEEDS TO BE

By Sean Ostruszka

PHOTOS BY CHARLES WALDORF AND PHOENIX MOORE

**I**t was only a matter of time for Michael Neal. After nearly a decade of expectations, close calls and watching others close to him take home the big trophy at the end of a tournament or the end of the season, Neal got his. On a postcard-beautiful August day in Massena, New York, after an incredible season on the Tackle Warehouse Pro Circuit, it was Neal's name called by the emcee. He who got to put his hands on a big trophy up on stage. He who held it over his head, smiled and posed for pictures as the sun gleamed off the hardware.

He didn't have to watch someone else like he had so many times before. No, this time Michael Neal was the champion. An Angler of the Year champion.

Finally.

Up on that stage and even after weeks of letting the victory sink in, Neal says it's the greatest accomplishment of his career, "by far." A true testament to his consistent style of fishing. After all, Neal prides himself on being consistent. That's how an introvert like him has managed such a successful career in a sport where outgoing self-promotion can be almost as important as catching fish.

So, yes, Neal winning Angler of the Year – and doing it by outdueling a legendary angler like Skeet Reese – means his time has finally come. He has arrived.



Neal had flirted with major championship wins multiple times in his career before wrapping up the Pro Circuit Angler of the Year title.

## TWO WINS A DECADE IN THE MAKING

Most anglers dream about a career like Neal's.

Nearly a decade of success, with six top-20 finishes in the points race across nine Pro Circuit seasons alone and a couple more on the Bass Pro Tour side. More than \$1.2 million in earnings. Thirty-four top-20 tournament finishes. Major sponsors. Significant name notoriety.

That alone is a hell of a resume; one most can only dream of.

But there was still something missing as he exited the stage in Massena, AOY trophy in tow. A big something: a tournament victory. Just one major tournament victory.

See, winning AOY was the first of two major feathers Neal was chasing to add to his cap. The other – a major tournament win – came about a month later on Lake St. Clair in the Bass Pro Tour 2021 season finale. Before that, Neal had never won a tournament above the Phoenix Bass Fishing League level, and that last one came in 2012. He has 33 Top 10s and finished second half-a-dozen times, but he'd never hoisted a big trophy for a single-tournament performance until that mid-September tournament on the big stage.

You know who had, though? Seemingly everyone around him.

Buddy Gross was a rookie and Neal's travel partner in 2016 when Gross took home a Tackle Warehouse Pro Circuit win on Pickwick Lake – a tournament at which Neal finished second. Fellow Dayton, Tennessee resident Andy Morgan – who Neal has known since childhood – got his morning coffee at Neal's tackle shop the morning Morgan won the Bass Pro Tour event on Lake Chickamauga in 2019. Even amid his greatest career achievement of winning Angler of the Year, the sport reminded him a day later of his seemingly constant, close proximity to victory when Cody Pike (again, a rookie and Neal's travel partner) won the final Pro Circuit event of the regular season on the St. Lawrence River.

"I'll be honest, winning Angler of the Year was a little relief because it'd gotten to the point where I didn't think I'd come out on a top of anything," Neal admits. "Seriously, I went [into the final event on the St. Lawrence] thinking I'd finish second [in AOY points] because it'd happened so many times before."

That kind of bridesmaid-but-never-the-bride scenario can really wear on an angler after a while. It definitely did for Neal at first, especially when he felt he did everything right and fluke circumstances intervened to allow another angler to surpass him the final day.

"The ones where dumb luck beats you sting, where you did everything right and you still lose," Neal says. "Greg Hackney winning at Pickwick with his Power-Poles down in the middle of summer was one like that. But now it's happened so many times that it's like any other day. Even when Jacopo [Gallelli] won at the Potomac earlier this year (after an insane 20-pound final day that left Neal again finishing second), I knew I did everything I could.

"It just wasn't my time."

Yet.



PHOTO BY ROB MATSUURA



## PADDLING FURIOUSLY

Watch a duck on the water. They're beautiful, calm, controlled – the picture of serenity as they seem to barely make a ripple. Beneath the water, though, it's chaos. Big, webbed feet paddling like pistons to get wherever the duck needs to go.

That's Neal.

"People ask me all the time how I stay so calm," says Neal, who is known for his stoic, quiet demeanor, especially on the water. "What they see on the outside versus what's going on inside is totally different. I'm a total wreck inside."

Part of that comes with being an introvert, but part of it also comes from pressure. And most of that pressure he puts on himself, he says.

You'd think after nearly a decade of success he'd be utterly confident in his abilities and his instincts. He's not. Neal admits he's never ended practice and felt good about it; like he had a great pattern that was sure to propel him to victory.

"I always feel like I didn't find enough," Neal explains. "Even if I find four great patterns, I always wonder if I missed a fifth that was better. My mind never stops wondering 'what if?' and I put so much pressure on myself."

That restless mind is also a big part of his success, because Neal is often so prepared for just about anything.

Take the Lake Murray event in April. Neal started offshore on the lower end, but on Day 2, he realized he might need to make a change and ran all the way up the river to a stretch of laydowns he'd gotten a bite on during practice. One bite. As it turns out, that stretch would get him enough kickers the rest of the event to once again be so very close to victory (Neal went on to finish third).

The thing is, Neal is an offshore guy. It's what he's best known for, and he was fishing a lake that was primed to be won offshore based on the time of year. He'd even scored a previous Top 10 on Murray fishing offshore. He easily could've devoted his entire practice to dialing in the offshore bite and called it good.

His mind just wouldn't let him, and it ended up working out.

Of course, for every time Neal's mind is his aid, there are often as many times it proves to be a hindrance, most notably when it comes to taking risks.

"I never take a whole lot of chances," Neal admits. "Taking a big risk gets my mind going like crazy. It goes against my entire nature."

"The thing is, on the final day of a tournament, you need to take those gambles and be more aggressive. It's why you see so many of those 'Hail Marys' work out for guys, and they win. That's not easy for me. I'm working on it, and it's going to take a lot of work."

Fortunately, Neal never shies away from the work.

Events like his close call at Murray prove to Neal in little ways that he can push himself further. Winning Angler of the Year proves he has the skills to push himself further. The 2021 season as a whole proved to him that he can trust himself further, to do the things to finally get that tournament win he's always sought.

So yes, Neal finally has a big trophy; one he's exceptionally proud of – two, in fact. And now it's a matter of getting the next one.

And as long as Neal keeps doing what he's always done, his time isn't just coming — it's already here.

Lake Murray



PHOTO BY KYLE WOOD

## 2021 IN NEAL'S OWN WORDS

One announced his presence with authority. The other took a little to get going. Skeet Reese and Michael Neal ended up battling until almost the final day of the season for the Angler of the Year title. In the end, Neal did just enough to edge out Reese in one of the tightest AOY races in recent memory. Here's a look at how Neal got there.

### LAKE OKEECHOBEE — 22ND

"There was nothing too exciting about this event," Neal recalls. "I just did what I always do in Florida - what I do best, and that's [fish the] wind. A lot of guys get caught up in that flipping bite, and I just put a swim jig in my hand and fished the way I wanted."

### LEWIS SMITH LAKE — 33RD

"I caught five keepers each of the first two days," he says. "That's it. And on the first day, I caught my fifth with about five minutes to go. I had this foundation I'd found and fished so many times and had only been able to catch fish off it in practice. Well, I hit it on my way in and caught a 3-pounder. Without that fish, I can kiss Angler of the Year goodbye."

### LAKE MURRAY — 3RD

"I thought the first day I was in really good shape until I got to weigh-in and realized the guys caught them a lot better than I thought they would," Neal says. "So Day 2, after starting offshore, I decided to take a little gamble and run up the river to a stretch of laydowns I got one bite in practice. I got up there and caught a 4 1/2-pounder on a vibrating jig that ate it with about a foot of line out. I set the hook and boat-flipped her in one motion. After that, I'd start offshore and then run up the river to get some bigger bites."

### LAKE EUFAULA — 11TH

"I caught 9 1/2 pounds the first day, and I'm mad at the world," Neal explains. "Then, Day 2 happens, and it's one of those days where everything went right. I went to one place I caught one small fish in practice and caught two 3 1/2-pounders on a deep crankbait. And it was like that all day."

### POTOMAC RIVER — 2ND

"I knew what I was going to do going into this event: I was going to find one area and hunker down in it," Neal says. "I found one stretch of grass where I caught all my fish, and it nearly worked out if [Jacopo Gallelli] didn't have the most incredible final day."

### ST. LAWRENCE RIVER — 11TH

"This one was so stressful because I didn't even know if Skeet was going to show up (he flew back from a family vacation in Italy to fish the event)," Neal recounts. "Plus, smallmouth are not my forte. They're like ghosts. I just never truly understand them. Fortunately, a few weeks before I fished a Bass Pro Tour event there and did OK, but I realized the area I was in a lot of fish got caught."

"I decided to go back and make a milk run in that area, and it worked, but still there were two fish that stood out that helped me get Angler of the Year. On Day 1, I cast out and I watch on my screen a fish eat my bait on the way to the bottom. It gets off quick, but instead of reeling in, I dropped it back and the fish followed it all the way to the bottom and ate it. It was a 5 1/2-pounder. Then, on Day 3, I was re-tying and was on the trolling motor setting myself back up, but I steered wrong and ended up on a grass flat. As I was working my way off it, I pitched to the edge and caught a 4 1/2-pounder that pretty much sealed it for me." ■

Potomac River



PHOTO BY ROB MATSUURA

St. Lawrence River



PHOTO BY KYLE WOOD

# WE HAVE THE GEAR

★★★★★

**COMFY!** - *Stephen R.*

"I wore this during a tournament when it was about 90 degrees. First thought - I need more! Very comfortable!"



## LONG SLEEVE PERFORMANCE TEE

Your go-to on the water. Lightweight, highly breathable, and moisture-wicking.



Get this shirt and more at [thmarine.com/FallApparel](https://thmarine.com/FallApparel)

# MISSISSIPPI RIVER ROOTS AND A TITLE 34 YEARS IN THE MAKING

**JIMMY WASHAM'S LIFE — AND  
BASS FISHING DREAMS — BEGAN  
700 MILES DOWNSTREAM**

*By Joe Sills*

**J**immy Washam Jr. rushed home when he got the call. As he sped through the Memphis suburbs, the frantic voice of the babysitter rushed through his head. His little boy, she said, had some sort of parasite, evidenced by an unnatural “alien creature” freshly deposited in his child’s diaper.

The child in question was the 2021 Tackle Warehouse TITLÉ winner, Jimmy Washam III. And the alien parasite, which manifested itself some three decades ago? A 6-inch soft plastic lizard that he’d been playing with in dad’s boat.

“Dad couldn’t stop laughing,” recalls the younger Washam, who doesn’t remember eating the lizard, but does recollect using it to play with freshly caught bass in dad’s livewell the day before.

Thus began a lifelong love of bass fishing that culminated in capturing the sport’s most memorable trophy in August – the red and silver championship belt, seemingly ripped from the shelves of Memphis-born wrestling legend Ric Flair’s trophy room, that belongs to the TITLÉ champion. The strap came with a \$200,000 payday that would make The Nature Boy himself proud.





## 'WHEEL 'EM IN' WASHAM

For Washam, 34, the road to becoming TITLÉ champion began early in life. By kindergarten, he was pitching a baitcaster around the small reservoirs and Mississippi River backwaters surrounding Memphis. Often, he and dad would make the short drive down to the Mississippi Delta to the muddy, timber-filled waters of Sardis Lake, an impoundment more widely known for panfish than for bass. Day after day, year after year, the two Washams would ply the waters of that nondescript lake until the future champion earned a nickname: "Wheel 'Em In."

Dad, you see, was an adept bass angler who won his fair share of tournaments in the 70s and 80s, according to his son. While the tournament days died down with the onset of fatherhood, the older Washam still managed to spend countless hours on the water, baby in tow, and for a period of time in the early 90s, locals within earshot of the lake knew when the Washams had a bite thanks to young Jimmy.

"Everyone knew when dad was catching fish," he says. "Because every time he would hang one, I would run to the front of the boat and scream, 'Wheel 'em in!'"

Before long, young "Wheel 'Em" was growing up, and the father-son duo were fishing local charity events like the St. Jude Bass Classic and taking their crack at regional tournament trails in the Mid-South. They were finding success, too, forging a path that would permanently plant the tournament fishing bug in the young man's blood.

## SOME COMMUTE REQUIRED

But Memphis is not situated on a major reservoir. Though it sits beside the Mississippi River, the main channel there is torrid and littered with dangerous debris, whirlpools and barges. Its sandy bottom, a labyrinth of ever-changing submarine dunes and pits, is more akin to the Sahara Desert than to Sam Rayburn.

To become a professional bass angler from the Bluff City, you've got to commute. You've got to really want it.

By his early 20s, Jimmy Washam was juggling a fledgling career at Bass Pro Shops as an archery and hunting supervisor. This was long before the Memphis Bass Pro Shops was in a towering, 300-foot-tall pyramid. Rather, the location Washam manned was carved out of a converted Walmart. It shared a strip mall with a cowboy-themed nightclub and a barbecue joint.

In 2012, after several years at Bass Pro Shops, Washam opted for a career change. At 25, he traded fluorescent lights for squad car lights and joined the sheriff's office of a neighboring county.

"I didn't want to work inside," he says. "That was the best route for me to go do something that I saw as exciting at my age, but also didn't require a crazy, long-term college degree. It was a life improvement I could make immediately."

By then, Washam had experienced enough tournament success with his father to really dream about pursuing professional bass fishing as a career. But his new lifestyle improvement came with a catch – it would take Washam three full years of service at the sheriff's

department to compile enough time off to fish a major tournament trail.

In the meantime, he'd have to pursue his dream on weekdays, making the two-hour drive to Pickwick Lake in a battered 1998 Chevy Z-71 with a Bass Tracker in tow.

Growing up near the Mighty Mississippi, Washam had long known the secrets of the remote river oxbows and cypress swamps near home. At nearby Sardis Lake, he'd become well-acquainted with the basics of bass fishing on a reservoir, but he knew securing big-time tournament wins meant learning the secrets of boating big bags on legendary bass fisheries as well.

"My dad always looked at Pickwick as too far [away]," Washam recalls. "It was an hour to Sardis and two hours to Pickwick. At Bass Pro Shops, I had met some guys who were willing to go that far.

"At the time, I didn't know what finesse fishing was. I'd had the same spinning rod since I was 10 years old, and it's the very same one I took up to Pickwick on that first trip when I was about 22. Once we started catching fish on shaky heads, we fell in love with Pickwick, and it became basically the only place we went to go bass fishing."

The blue-green waters of Pickwick proved formative for Washam. There, he not only pieced together the puzzle of finesse fishing, but also taught himself how to triangulate offshore ledges and how to fish grass and current. With just a handful of fishing buddies, he relied on magazines and website articles to learn the ins and outs of tournament-winning patterns and techniques. And because his fishing was mostly limited to weekdays, Washam usually had the lake to himself.

## TAKING THE NEXT STEP

In 2015, Washam finally accrued enough time off to fish as a co-angler in the Phoenix Bass Fishing League. That experience stirred a commitment to replace his trusty Bass Tracker with a used 1998 Ranger.

"Really because it could keep two limits alive at once," adds Washam. "I was fishing competitively out of the Tracker, but I couldn't keep ten fish alive [in its livewell]."

The gamble paid off when Washam took home the top prize in his second BFL event, earning enough to pay off

most of his bass boat and set him on a course toward fishing the Toyota Series the following year. After battling through boat problems at two major events in the Toyota Series, Washam would eventually qualify for the Tackle Warehouse Pro Circuit in 2020 by virtue of a third-place finish in the Central Division AOY standings (another title he went on to claim in 2021).

At the pro level, Washam's first event wasn't as successful as he'd hoped. Finishing 69th at Sam Rayburn, a \$5,000 check in hand, he started an eight-hour drive home, reliving his missed opportunities before deciding then and there to start fishing on instinct.

Eventually, Washam would rebound and come within a breath of winning

the 2020 Polaris Rookie of the Year crown hoisted instead by Kyle Hall. That loss, he admits, still stings. Nearly 12 months to the day that he watched his ROY hopes slip into the Mississippi River, though, Washam left the Upper Mississippi River a champion, thanks in part to his riverine childhood.

"Building a lifetime of experience catching shallow river fish certainly helps," Washam says. "In many ways, fishing the Mississippi River down South and up North are completely different experiences, though. At La Crosse, the fish will use the main river channel, but I've never in my life caught a bass in that channel down South. They're always in an oxbow or a slough or a pocket."



"Wheel 'Em In" Washam got his start fishing around the family's home in Memphis with his dad Jimmy Washam Jr.

PHOTO COURTESY JIMMY WASHAM

# GOOGAN

BAITS

COLOR  
DOMINANCE



BANDITO BUG

GREEN PUMPKIN PURPLE



EXPLODE TOAD

FIRE CRAW



KRACKIN' CRAW

CHARTREUSE PEPPER W/GREEN FLECK



TRENCH HAWG

CALIFORNIA CRAW

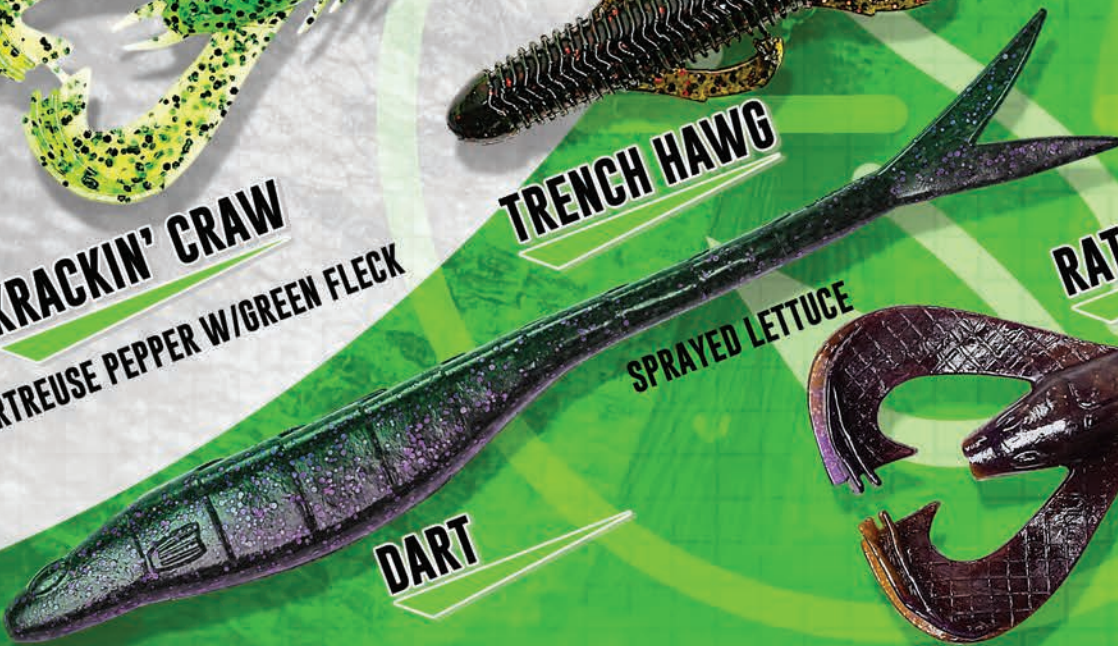

DART

SPRAYED LETTUCE



RATTLIN' CHUNK

PB&J



## COMING FULL CIRCLE

Washam leaned on a pocket similar to those in his home waters to take home the TITLE.

In practice, he stumbled upon a closing dam while trolling to a backwater away from the main river channel – almost literally.

“I had the trolling motor pinned down, rolling down the bank,” he explains. “I had recently come off pad over deep water and left my motor trimmed down. Suddenly, I felt my lower unit slam against a rock jetty. It almost threw me out of the boat.”

Shaken by the experience, Washam glanced down at his sonar unit to see a 35-foot-deep hole behind the dam. Normally, he’d expect to find a shallow area behind a similar structure on the main channel, but this unique honey hole presented an opportunity to sack larger-than-average bass.

Washam made it to the Knockout Round without needing to use his secret spot. Then, during the closing minutes of the Knockout Round, he called on it to boat more than 9 pounds of bass: a 5-pounder and another about 4 1/2.

“It sounds dumb, but my adrenaline was going, and I was pumped up,” Washam says of those two fish. “I looked at the camera boat that day before I rolled out and told them that there was an 18-pound bag in the hole. I told them I was going to come back the next day and win the tournament.”

By the end of the following day, Washam had wheeled in 17 pounds, 15 ounces from that spot to seal a monumental victory. After six days of competition and six years of chasing a major tournament win, Jimmy Washam III stood on top of the world. Back home, his 73-year-old father was tuned in. Surrounded by friends and family, he must have glowed when his lifelong fishing partner held the shimmering championship belt over his head.

“It was surreal,” Washam adds. “It’s a once-in-many-lifetimes event. I think back to starting from the ground up without a lot of financial backing, working at Bass Pro Shops, working in the squad car, fishing out of that aluminum Bass Tracker and steadily working my way up. It took a few days to sink in, but now I have a feeling that all of that hard work has come to fruition.”

The victory, of course, came with more than a belt. Washam’s \$200,000 in winnings will be enough to usher in the conclusion of his law enforcement career by the time this story prints. Soon, the Washam household will relocate from Covington, Tennessee to a quiet spot on the shores of Pickwick Lake, where Washam plans to plot a defense of his TITLE, launch a guide service and make a run at the Bass Pro Tour’s REDCREST.

In addition, he’ll have a chance at another prestigious title when he fishes the Toyota Series Championship on none other than Pickwick Lake at the end of October.

As for the TITLE strap itself? The belt will sit in a place of honor, where it will likely conjure one more memory whenever someone dusts it off the shelf.

“Dad and I went to a wrestling show together when I was four or five years old,” Washam recounts. “I remember seeing Ric Flair and his glittering, gold belt.”

Now, Jimmy Washam Jr. and Jimmy Washam III have a championship belt of their own – one packed with enough memories to last a couple of lifetimes. ■



# FAVORITE

*future of fishing*

THE ULTIMATE PRO SIGNATURE SERIES

EVINRUDE

THE GOAT

NATHAN MORGAN

FLIPPING STICK

Bill Lewis

HEX

FAVORITE

future of fishing

SUMMIT

Brett Cornell

1st EDITION

FAVORITE

PERFORMANCE BASS BOAT

GENERAL

ZACK BIRGE

JUST

FAVORITE

STOCK STICK

BRIAN LATIMER

JVD FISHING

LURE LOCK

VANDAM

JONATHAN

FAVORITEUSA.COM

# MASTERS SERIES



## HOLLOW-BODIED FROGS

IN EVERY CRAFT, THERE IS A MASTER: AN ARTIST, PLAYER OR PERFORMER OF CONSUMMATE SKILL WHOSE WORK SERVES AS A MODEL OR IDEAL ...

*As told by Dean Rojas*

PHOTO BY PHOENIX MOORE

**I** can't remember the first hollow-bodied frog I ever saw, but those early frogs were never a big part of my fishing. It was just too hard to hook and land bass on those lures. Then, in 1999, I was working with a photographer, and he wanted me to put one of those early frogs in a bass' mouth for a picture. I did, and that photo ran as a cover shot, even though I didn't catch that fish on a frog. It got me thinking about those lures and how they could be improved.

Later, a friend showed me how he was skipping a Sumo Frog under docks at Lake Havasu. It was a fun casting challenge - to skip a lure as far under a dock or overhang as possible and get it through all kinds of cover. That's when I started to see the possibilities of the hollow-bodied frog, and I really started working on my technique.



“WHEN IT COMES TO FROG GEAR, YOUR LINE HAS TO BE BRAID, AND I ALWAYS RECOMMEND THAT IT NEEDS TO BE AT LEAST 60-POUND-TEST.”

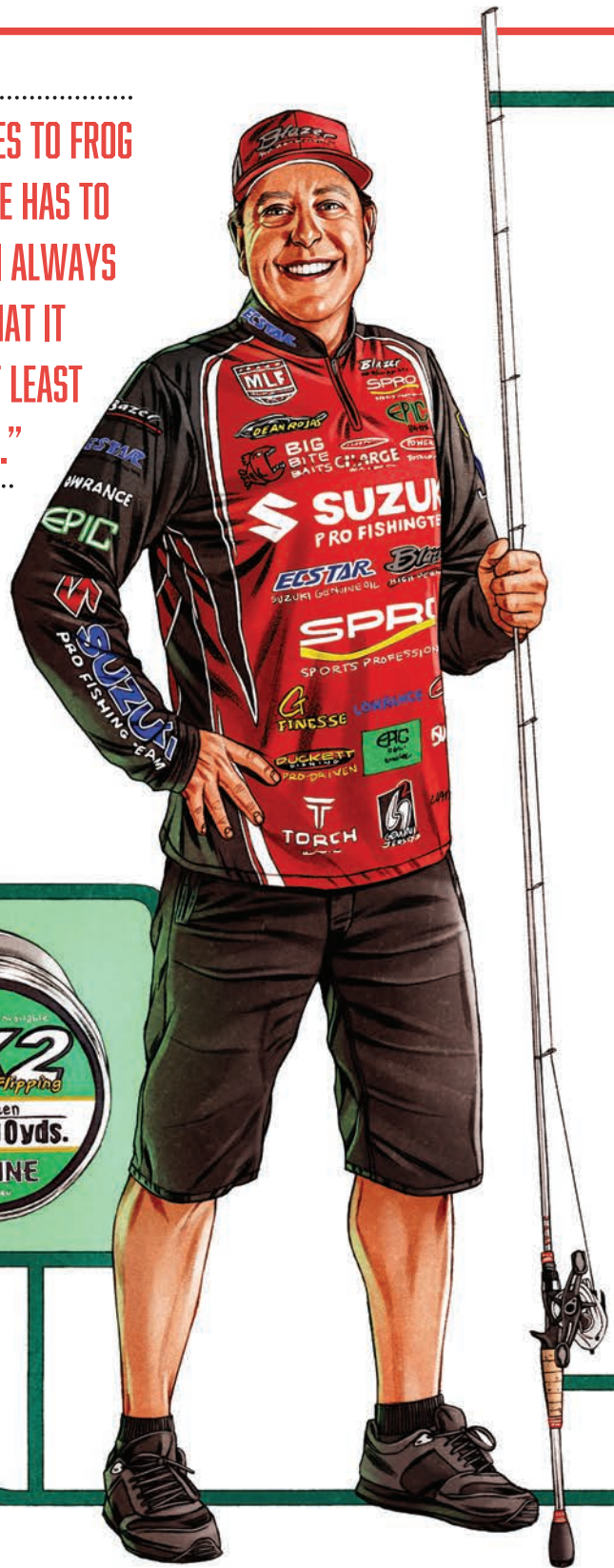
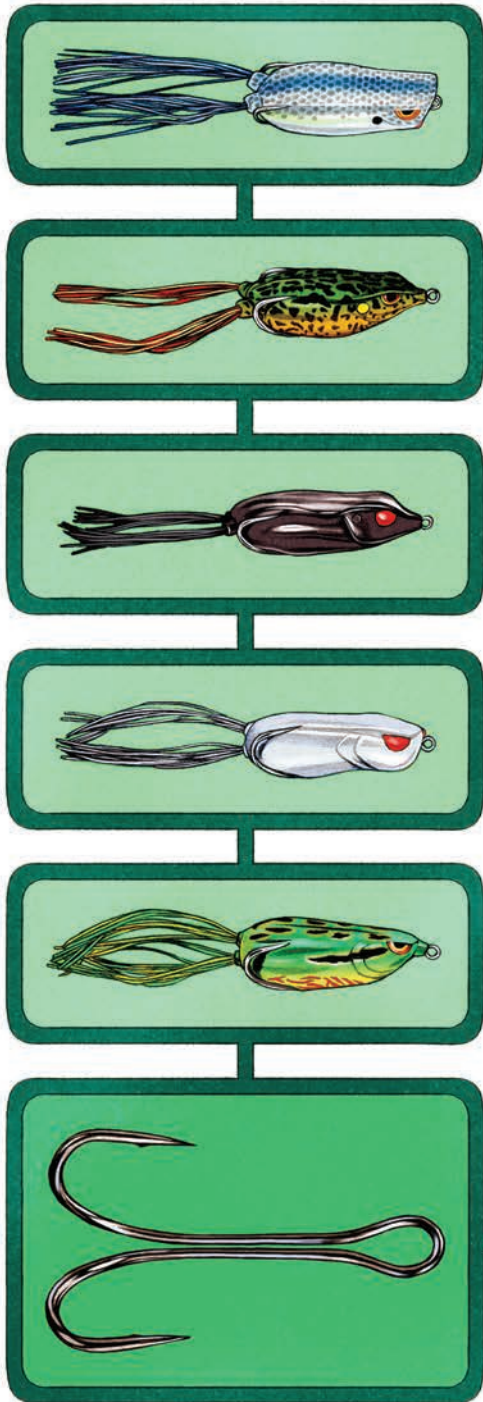

## HIGHLIGHTS

In 2004, I led the second day of the Bassmaster Classic on Lake Wylie in North Carolina, and I caught my key fish on a hollow-bodied frog. Unfortunately, my pattern didn't hold up well enough to win, but it brought the lure to the attention of the people at SPRO, and they asked me to design the

perfect frog. They put no restrictions on me and told me they'd use the best components anywhere to create the lure I wanted.

The result was the SPRO Bronzeye Frog 65. It went on to win Best Freshwater Soft Lure at ICAST in 2005, and it's been the best-selling frog on the market ever since.

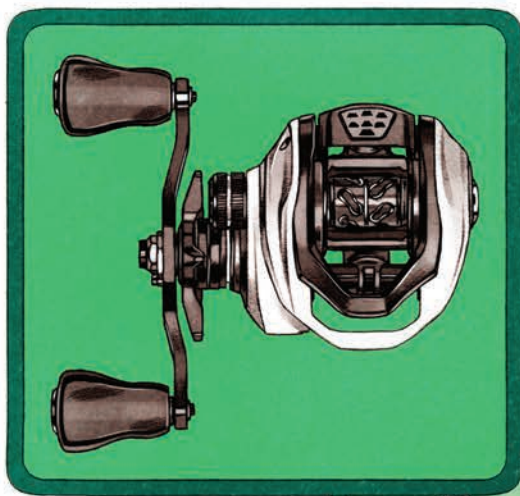

“THERE’S A RISK-REWARD RELATIONSHIP WITH FROGGING. IF YOU DON’T TAKE SOME CHANCES, YOU’LL NEVER CATCH THE BASS YOU COULD BE CATCHING!”

## WHEN

A lot of people ask me, “When is the best time to throw a frog?” My answer is always the same. I tell them to keep an open mind. The frog can be good anytime.

If you’re a tournament angler, it might not be your best bet to win in February or March, when the water is cold, but it could still make for a fun day. I’ve had great days with the

frog all throughout the year because I’m open-minded about how I use it. It might not be the right bait for the entire day, but it could be the perfect bait for a few strategic casts, and there are almost always a few places you’ll fish over the course of a day where no other lure can go.

Remember that the hollow-bodied frog is a topwater bait; it’s exciting, the strikes can be explosive, and it almost never gets hung up. Then you start to realize that you can throw it whenever you want.

## WHERE

I designed the Bronzeye Frog 65 as a “target” bait rather than as a mat-fishing lure. It’s perfect for everything from open water to light grass, holes in heavy cover, skipping under docks and piers – and all without getting snagged.

We have other frogs that might be better under certain conditions, and we’ve designed – or we’re working on – other frogs for just about any situation an angler might encounter. They all have one thing in common: You can throw them absolutely anywhere a bass might live.

## TACKLE

When it comes to frog gear, your line has to be braid, and I recommend that it be at least 60-pound-test. I designed Sunline FX2 exclusively for frogging and flipping. It casts really well and it’s abrasion resistant. It’s everything I need for frogs or flipping.

I’ve also designed several rods for frogging, and I’m working on a new series that should be out in the next year. Basically, I like a 7-foot, medium-heavy casting rod with a fast tip for most of my frog fishing. If I’m in extremely heavy cover or using the big SPRO King Daddy, I’ll go to a 7-foot-4 heavy-action model, also with a fast tip.

I like a casting reel with lots of line capacity and a gear ratio of at least 7:1. A faster reel can be good, as long as it doesn’t cost you power. It takes a lot of torque to pull a big fish out of heavy cover, and you may lose that with some faster reels.

## LURES

We’ve added a lot of frogs to the SPRO lineup since introducing the Bronzeye Frog 65 in 2005. We have the Bronzeye Pop, the King Daddy, the Bronzeye Shad, the Spot Shad, and more are coming. I’ve designed them all, and each has its applications and situations where it’s the best choice. All are equipped with 3/0, 4/0 or 5/0 Gamakatsu EWG frog hooks.

The Bronzeye Frog series skips and walks the best. It’s a target bait that comes through cover extremely well.

The Bronzeye Pop is a popping frog. Because of the cupped mouth, it doesn’t skip as well as the Bronzeye Frog, but it’s perfect when you need more commotion. It’s also great for beginners since it’s easy to use.

The Bronzeye Shad is a glide bait. It has a pointy head and a more passive action.

The Spit Shad is a compromise between the Bronzeye 65 and the Bronzeye Pop. It offers less surface disturbance than the Pop but more than the traditional frog body.

ILLUSTRATION BY MICHAEL HOEWELER



PHOTO BY JESSE SCHULTZ

The frog can't zig-zag from side to side unless there's some slack in the line. If your line stays tight or taut, it's going to pull the frog straight forward and not allow it to "walk."

The biggest complaint I hear from anglers just getting into frogging is that they miss a lot of strikes. Sometimes the bass aren't serious about eating the frog; sometimes they just want to kill it or get it out of their area, and sometimes they just miss it. Whatever the reason, there are a couple of things you can do that will help.

The first is to take a pair of pliers and bend the hooks out slightly. This will make the lure less snag-free, but it will increase your hook-up percentage. The second is to set the hook as soon as you see the strike. That's my default. When that doesn't work, it means they're missing the frog or toying with it. Try changing colors or frog styles until you find what they really want.

The King Daddy is our biggest frog at 90mm and 7/8 of an ounce. It's great when you want to move a lot of water or need a big meal to attract a big bass.

Frogs come in every imaginable color, including shades designed to imitate baitfish. SPRO offers the Bronzeye 65 in nearly 50 distinct color patterns, and they all catch fish. Although I carry a lot of colors, I keep my selection process simple.

Under dark conditions – early and late, cloudy or rainy – I like dark colors. If it's sunny and the water's clear, I go to baitfish colors that have scale patterns or a pearl bottom. And if it's partly cloudy, I go with natural colors that usually have some green in them.

Ultimately, I let the bass tell me what color they want. When you're dialed in, the fish will let you know.

## BASICS

The most important things to keep in mind when fishing a hollow-bodied frog is don't be afraid to throw it into extremely heavy cover, and don't be afraid to backlash your reel. It's hard to hang up a hollow-bodied frog, and you're definitely going to get some backlashes as you learn how to skip a frog into tight spots. But there's a risk-reward relationship with frogging. If you don't take some chances, you'll never catch the bass you could be catching!

The basic frog retrieve is "walking the dog," much like anglers do with hard lures like the Heddon Zara Spook. To do it, start with the right rod, which has a fast tip. I twitch the rod tip gently, but sharply, and after each twitch, I immediately throw the rod tip back in the direction of the lure to give it a little slack. That slack makes all the difference. It gives life to the frog.

## BONUS

SPRO frogs are ready to go right out of the package, but they're also easy to customize if you want something different from them. The first thing a lot of anglers do is trim the skirt legs on a frog. I do that, too, depending on how I want to fish that bait at that time.

Coming out of the package, the legs on the frog are very long. If you leave them long, the bait will wallow in the water more, and it will hinder the frog's ability to walk. This can be good in heavy cover. The shorter you trim the legs, the easier it will be to walk the bait and make it lively.

The most versatile length for the legs is about the same length as the frog body. I often take the legs and pull them toward the nose of the bait. Then I trim them at that length. It's a happy medium that allows you to do a lot of things well. ■



PHOTO BY PHOENIX MOORE

# GET OUT WHAT YOU PUT IN

THE ALL-NEW  
CROSSROADS® COLLECTION  
WITH TUFFSKIN NYLON



**YETI** BAGS

# BE EPIC

## TODAY



**Dean Rojas Kelly Jordan Scott Suggs Colby Miller**

**EPIC** CONTINGENCY PROGRAM **EPIC**

**TUNGSTEN**  
PURCHASE HAT  
AND STICKER  
TO GET QUALIFIED  
[epicbaitsfishing.com](http://epicbaitsfishing.com)



**BAITS**  
AT ALL THESE MAJOR  
EVENTS  
CLICK ON BANNER  
TO GET STARTED  
**BE EPIC TODAY**



**EPIC**  
TUNGSTEN

**Spinner Baits**

**Buzz Bait Burner**

**Buzz Bait Slow Roller**

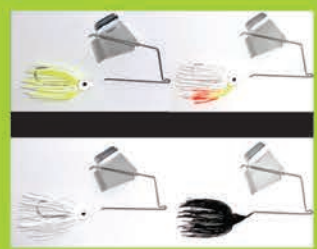

[epicbaitsfishing.com](http://epicbaitsfishing.com)

# THE JUICE

TACKLE, TOURNAMENTS & TIPS



PHOTO BY BOB WATSUMURA



PHOTO BY JOEY WHITE



PHOTO BY MATTHEW BROWN



PHOTO BY JOSH GASSMANN

**1. TACKLE WAREHOUSE PRO CIRCUIT PRESENTED BY BAD BOY MOWERS SAVAGE ARMS STOP 6 St. Lawrence River Presented by Abu Garcia**

July 29-Aug. 1

On a fishery like the St. Lawrence, huge swings in the standings rarely happen — when you're fishing somewhere so chock-full of quality fish that 33 anglers can weigh in at least 50 pounds over three days, there's not going to be a ton of separation on the leaderboard. That's why Tackle Warehouse Pro Circuit rookie Cody Pike's first major win on the national circuit was such a monumental victory. After three days, he found himself in second place, sure, but he also had a nearly 7-pound margin to make up on Championship Sunday.

Unfortunately for leader Joey Cifuentes (who weighed in multiple

bags over 24 pounds to that point), winning just wasn't meant to be. The Clinton, Arkansas standout, who typically does pretty well up North on smallmouth factories like the St. Lawrence, ended up weighing in his lightest bag of the week (12-5) to fall to third while Pike, who remained consistent throughout, weighed in his heaviest (22-3) to vault to the top and finish 1 pound, 12 ounces ahead of Junction City, Wisconsin hammer Matt Stefan.

Tucked away between the islands in Eel Bay, Pike was able to avoid the wind and current changes that plagued many in the Top 10 on the final day, allowing him to run his deep structure-related pattern to perfection. Pike had 40 to 50 rock piles "the size of his boat" which he bounced around between in that area, using the same presentation as nearly everyone else: a 1/2-ounce drop-shot tipped with a Berkley PowerBait MaxScent Flat Worm in green pumpkin.

**2. TOYOTA SERIES PRESENTED BY A.R.E. WESTERN DIVISION California Delta**

Aug. 3-5

A former college standout, Rocklin, California's Andrew Loberg knows a thing or two about how to catch fish on the Cal Delta (he won there in 2013 as a member of Chico State's fishing team) and finally secured his first major win with MLF in early August by staying flexible and rolling with the punches.

Loberg wanted to spend his week punching, but conditions called for something a little different, at least in the first few hours each day. With the tide high in the mornings, Loberg leaned on ChatterBaits, buzzbaits and walking baits to focus on current and fill out an early limit before the water dropped and he was able to start his punching program.

Despite weighing in just 13-2 on Day 2 to enter the final day in fourth place, the Delta was fishing tough for nearly everyone, and a massive 23-pound, 6-ounce bag was enough to bounce back in a big way and give Loberg the win by nearly 7 pounds over Michael Moreno.

**3. BASS PRO TOUR MERCURY STAGE SIX PRESENTED BY GOOGAN BAITS Lake Champlain**

Aug. 5-10

You'll have to search long and hard in the annals of tournament bass fishing to find a more dominant year than the one that Jacob Wheeler enjoyed in 2021. As if the Tennessee pro hadn't already accomplished enough by winning two Bass Pro Tour tournaments at two completely different fisheries —

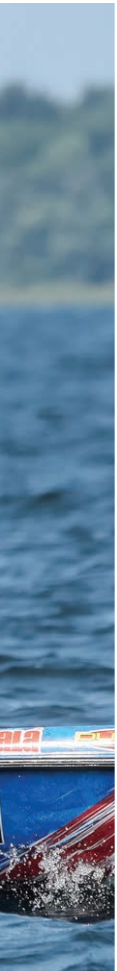

Lake Travis in Texas and the St. Lawrence River in New York — Wheeler one-upped himself in early August by claiming the red-and-silver BPT trophy at Stage Six on Lake Champlain as well.

In doing so, Wheeler became the first back-to-back champion in the league's brief history and the only angler to win three events in a season en route to his first Angler of the Year title.

Wheeler did it in the kind of cagey style he's perfected in 2021, quietly working his way through the early rounds of the event and then putting the pedal to the metal on the final day to win by just over 30 pounds. He did it just as you'd suspect, locating fish on forward-facing sonar, working a drop-shot and expanding his area throughout the day to stay on schools of fish as they roamed around the flats.

**4. TACKLE WAREHOUSE TITLE PRESENTED BY MERCURY**

**Mississippi River**  
Aug. 17-22

Pro Circuit sophomore Jimmy Washam's bass fishing career has been nothing short of a meteoric rise to this point. He fished his first MLF tournament as a boater in 2016 (Phoenix Bass Fishing League Mississippi Division), jumped to the Toyota Series level in 2017, qualified for the Pro Circuit via the Series and made the jump to the Pro Circuit in 2020 (nearly winning Rookie of the Year), all while holding down a full-time job as a deputy in the Tipton County sheriff's office — a career he's now chosen to walk away from in favor of becoming a full-time guide on Pickwick Lake, thanks in no small part to his TITLE win in August.

Washam has fished the Mississippi River his whole life, but almost always well south of Pools 7, 8 and 9 (which played host to the TITLE) down near Memphis — a fishery that may as well be a different body of water entirely. To get comfortable and find his way on the Upper Mississippi, Washam had to rely on his experience and a little bit of good fortune.

Washam plied the waters of the Black River well into the Knockout Round, at which point, with the area drying up, he moved to a backwater with a "rock ridge" at the mouth where his trolling motor spooked some shad that he watched a bass come up and eat. He threw a bait in after the bass, caught a 5-pounder and a 4 1/2 and the rest is history. It's at that spot that Washam sacked up 17-15 for the largest bag of the tournament, a \$200,000 payday and a TITLE belt he'll cherish forever.

**5. ABU GARCIA COLLEGE FISHING PRESENTED BY YETI**

**WILEY X COLLEGE FACEOFF**  
**Detroit River**  
Aug. 21

Western Michigan dominated the fourth and final Wiley X College Faceoff event of the 2021 season by boating 44 bass for 109-8 to outpace Adrian College by 14 pounds, 11 ounces.

The duo of Mason Vernia and Kurt Antonowitsch relied on 3/8-ounce drop-shots tipped with Strike King Baby Z-Toos while Jack Simpson and Drake Van Dike did the same with Berkley PowerBait MaxScent Flat Worms. Both teams went to their high-percentage spots early in the event, plying deep rocks and grass with their drop-shot offerings and keeping a close eye on their electronics to locate and relocate schools of winning fish.



PHOTO BY CHARLES WALDORF



PHOTO BY COBI PELLERITO



PHOTO BY GARRICK DIXON

The Adrian College teams of Austin Tapley, Carter Ball, Aaron Jagdfeld and Jacob Emery managed to boat 32 bass for 94-13 to keep it somewhat close, but behind them, none of the three other qualifying schools managed to get within 35 pounds of the pair of Western Michigan teams in their eventual victory.

**6. TOYOTA SERIES PRESENTED BY A.R.E. NORTHERN DIVISION St. Lawrence River**

Aug. 26-28

Brothers Chris and Cory Johnston are widely regarded as a couple of the best Northern smallmouth anglers on the planet, so it really comes as no surprise that they finished first and second, respectively, in the penultimate event of the Northern Division season.

Chris' win was a blowout — he finished more than 6 pounds ahead of Cory — and, save for Justin Atkins having a monster week of his own (70-7), no one else was particularly close to the siblings. Chris outpaced fourth-place finisher Brent Anderson by 13 pounds, 8 ounces.

To weigh in bags of 25-7, 25-2 and 27-6, Chris spent hours running each day from takeoff at Massena all the way to Lake Ontario where he used an unidentified prototype worm on a 3/8-ounce drop-shot to hit a couple key spots in his roughly four hours to fish on the final day. Even after losing a 6-pounder and a 6 1/2, Johnston had more than enough in his livewell to get the St. Lawrence monkey off his back in a big, big way.

**7. BASS PRO TOUR CARPARTS.COM STAGE SEVEN PRESENTED BY COVERCRAFT Lake St. Clair**

Sept. 10-15

It's been almost impossible to escape Michael Neal this year. The Tennessee pro accomplished a career-defining goal in August when he claimed the Tackle Warehouse Pro Circuit Angler of the Year title (see page 44), but then one-upped himself a month later by decimating Bass Pro Tour records on his way to winning the regular-season finale on Lake St. Clair.

Neal entered the tournament only mildly confident in his practice, but by the end of his first qualifying day, he had discovered a group of fish on a mile-long grass flat at the mouth of the Detroit River/Lake Erie that he knew he would win on. Alternating between a bluegill-colored crankbait, a deep-diving jerkbait and a drop-shot, Neal piled up 223 pounds in two qualifying days to advance straight to the final day.

Neal then crushed 168-11 of smallmouth in the Championship Round, winning by more than 75 pounds and obliterating the MLF record for margin of victory. Neal cleared the \$300,000 mark in winnings in 2021 to complement his AOY and BPT championship trophies.

**8. TOYOTA SERIES PRESENTED BY A.R.E. NORTHERN DIVISION Potomac River**

Sept. 16-18

As someone with ample experience on the Potomac River, Thomas Wooten understands how crucial it

is to make adjustments from day to day and hour to hour on the tidal fishery. On Day 1 of his Potomac win, Wooten opted for a buzzbait and swim jig around eelgrass to weigh in a steady bag of 12-12. He started with the same approach on Day 2, but the bite was waning and the punching bite — which Wooten really wanted to rely on — wasn't the ticket either, at least for more than a few good bites.

Instead, the homebuilder who hails from Huddleston, Virginia turned to a Booyah Pad Crasher and went to work, eventually weighing in a massive 18-pound bag to vault into the Top 10 and give himself enough leeway to seal the deal with 14-6 on Championship Saturday.

While many other anglers tried the frog, Wooten found the key to success with his Pad Crasher: working it as fast as his tiring arms would allow. His fish didn't want a slow, lazily walking presentation. Instead, Wooten twitched and "stroked" the frog to elicit reaction strikes and total 45-2 over three days, edging out Day 1 and 2 leader Aaron Dixon by 8 ounces for the victory. ■

WILEYX.COM  
OFFICIAL SPONSOR



# GO | CONFIDENTLY

Edwin Evers / Photo: MLF

## CAPTIVATE™ COLOR REDEFINED

Our CAPTIVATE™ polarized lenses filter light to enhance vision with vivid detail and vibrant contrast. ANSI-rated, they offer maximum protection and clarity so you can see clearly — above and below the water. Learn more at [wileyx.com](http://wileyx.com).



WX GRAVITY





## WILEY X CLIMB SUNGLASSES

By Matt Williams

PHOTOS BY BRANDON ROWAN

Just about everything we do on and off the water hinges on our ability to see. Protecting that precious gift with military-grade eyewear built to take a beating has always been a priority at Wiley X. The company recently stepped up its game with a new polarized lens technology called “Captive.” The technology is advertised to improve vision by producing exceptional optical clarity, enhanced colors, contrast and better depth perception while offering top levels of protection.

The Climb is one of several new frame designs offering the cutting-edge lens technology. I checked out the matte grey model with blue mirror lenses to find out just how exceptional the new offering really is.

### First Impressions

The sporty-looking shades feature a wrap-around frame design and wide temple arms that help prevent pesky peripheral (side) light and projectiles from sneaking in while providing a snug, comfortable fit. Rubber nose and ear-piece pads reduce slippage and help

keep the rectangular-shaped lenses riding close to the eyes. The temple arms are stamped with the WX logo. Wiley X throws in a zippered hard clamshell case, lanyard/rubber grips and a microfiber bag that doubles as a cleaning cloth.

### In Action

I found plenty to like about the WX Climb.

For starters, the lightweight frames provide all-day comfort and optimal protection while the high-tech Captivate lenses are a pleasure to look through whether on the water, driving down the road or working outside. As optics go, I’d put these lenses in the same league as those found in some other top name-brand shades that cost significantly more, including glass.

The blue mirror lenses do a great job of filtering out blue light and squelching reflective glare, making them ideal for fishing in bright skies on big water. As advertised, the lenses keep most colors neutral while giving greens a little extra pop.

The lenses and frames both meet restrictive safety and impact resistance

standards set by the American National Standards Institute (ANSI). That bumps the confidence needle up a notch or two.

Still another plus is the scratch-resistant lenses, which are really easy to clean thanks to a proprietary oleophobic coating that keeps dust, oil and other gunk from sticking.

### Final Thoughts

There are plenty of high-quality sunglasses on the market to choose from. If you’re looking for a pair that can take some hard knocks, offer good looks and great optics for under \$175, you can’t go wrong with the WX Climb.

### Performance Advice

Take care of the glasses and they will take care of you. Here are some basic tips:

- Wiley X recommends cleaning with the provided microfiber cloth, soft cotton cloth and warm water. Avoid ammonia, bleach, vinegar or window cleaners that could strip away the coatings on your glasses.

## LENS TECHNOLOGY:

Innovative lens technology called "Captive" produces vivid colors and crystal-clear clarity while improving contrast, depth perception and blocking UV and HEV rays that can damage your eyes. The scratch-resistant lenses have a special oleophobic coating to help prevent dust and other debris from gathering, which lends to easy cleaning.



## DURABILITY:

The frames and lenses meet or surpass the strictest ANSI requirements for optimum durability, protection and safety. Both can withstand the blunt impact of a 1/4-inch steel ball traveling at 150 feet per second.

- Using tissues or the tail of your shirt to clean the lenses could cause scratches.
- It's a good idea to wet the lenses before cleaning. Wiping dry lenses could eventually cause abrasions.
- Always store glasses in the hard case or another safe place when not in use.
- Never lay the glasses face down.

## Applications

- Use in big sun and bright skies
- General daytime outdoor activities
- Reduce sun glare, road glare and eye strain while driving
- Everyday wear

## HITS & MISSES

- + Shatter-resistant construction
- + Lightweight
- + Comfortable but snug fitting
- + Attractive design
- + Wrap-around frames for better all-around protection
- + Prescription capable lens
- + Comes with hard case, leash cord/rubber grips and microfiber bag
- Only available in one size (Medium/Large)

## >> OPTIONS GALORE

**Styles and Sizes:** Wiley X makes sunglasses in 42 attractive frame styles for men and 13 for women in multiple sizes with three different lens collections and 13 lens colors in three categories including fishing, hunting and shooting. If you can't find something you like from Wiley X, what you're looking for probably doesn't exist. All lenses are prescription capable.

## DETAILS

**Frame Colors:** 3  
**Lens Colors:** 3  
**Frame Sizes:** 1  
**Hard Case:** Yes  
**Leash Cord:** Yes  
**Rubber Ear Grips:** Yes  
**Microfiber Storage Bag:** Yes  
**MSRP:** \$160.00  
**Contact:** [wileyx.com](http://wileyx.com). ■

YOUR PARTNER IN PROTECTION

# 15 YEARS ON NIGHT SHIFT.

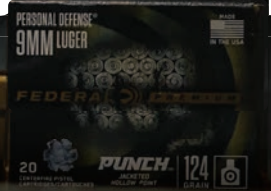

Ready to return home to her family after an overnight shift in a world that keeps getting crazier, Sara depends on Federal® as her Partner in Protection. No one else gives you the knowledge, training and the most effective and trusted family of defense ammunition. Buy now at [Federalpremium.com](http://Federalpremium.com)



I CHOOSE  
FEDERAL

**Sara Berg**

Age 38 / ER NURSE, WIFE, MOTHER OF 4

Everyday Protection » Punch™



FEDERALPREMIUM.COM

**FEDERAL**

# The Toughest Protection In All Conditions.

## LUCAS OIL MARINE PRODUCTS



Lucas Oil Marine Products contain a special blend of additives that protect expensive engines and gear against moisture, rust and corrosion.



# LUCAS OIL

LucasOil.com • 800.342.2512

**Will Not Void Manufacturers' Warranties.**

# THE COLORS OF FALL CRANKIN'?

*VanDam, DeFoe cover the color spectrum for October, November crankbait success*

By Tyler Brinks

PHOTOS BY BRANDON ROWAN



**F**

all is a time of transition as the warm weather of summer slowly starts to give way to cooler temperatures and shorter days. Whether that

means focusing more on hunting or adjusting your fishing approach, October and November arrive with changing conditions that affect the habits of all species, including bass.

The term “fall colors” generally refers to the changing hues of leaves as they switch from greens to vibrant yellows and oranges, but the fall change also signifies a shift in gears when it comes to crankbait colors.

Kevin VanDam and Ott DeFoe have a lot in common: They’ve each claimed Bass Pro Tour victories and Bassmaster Classic wins, and each has a deep love for fishing crankbaits – so

much so that they’ve both been deeply involved in the development of some of the most popular crankbaits on the market today from Strike King (VanDam) and Rapala (DeFoe).

“Cranking just suits my style,” VanDam admits. “I’m a power fisherman, and I love to cover water. A crankbait is the best tool I can think of for that.”

Both VanDam and DeFoe are certainly very versatile in their techniques.

**“THE IDEAL SITUATION IS WHEN YOU CAN FIND FISH ON THE SHALLOW FLATS CHASING SHAD.”**

VanDam has racked up over \$6 million in tournaments winnings fishing everything from a drop-shot to a spinnerbait; DeFoe is quickly closing in on the \$3 million mark with similarly diverse baits. That said, cranking has accounted for a high percentage of their success as professional anglers

And while DeFoe and VanDam have picked up the bulk of their major crankbait-centric tournaments wins in the spring or early summer, both count the fall months among their favorite times to fish a plug.

### ALL ABOUT THE BAIT

It's no secret, but finding baitfish is one of the biggest keys to success in the fall, as bass will follow the transition of shad every autumn.

“Fall is one of the best times to fish a crankbait because the fish are scattered and chasing bait,” DeFoe confirms. “This time of year, you have big shad that were spawning earlier this year and all of those that hatched, so

shad are everywhere. I'll always start with shad colors because that's predominately what the bass are eating.”

VanDam echoes that sentiment and sticks with shad as his primary color patterns before switching to different hues of crawfish patterns as the water cools.

“The ideal situation is when you can find fish on the shallow flats chasing shad,” he says. “That and looking at my electronics or looking around with my eyes for balls of shad is what I'll be doing all fall until the transition to winter. Then the bass start to feed heavily on crawfish when the water reaches the mid-50s again.”

While DeFoe and VanDam both rely on shad patterns for most of their fall cranking, they don't just pick one – they make miniscule adjustments based on the water clarity, weather conditions and a handful of other factors.

### SHAD PATTERNS FOR CLEAR/STAINED WATER

Strike King Series 5 Crankbait in summer sexy shad, Rapala Ott's Garage Slim 06 in big shad, Rapala Ott's Garage Slim 06 in live river shad, Strike King KVD 1.5 Deep Squarebill in natural shad, Rapala DT4 Crankbait in green gizzard shad.



### ADJUSTING FOR WATER CLARITY

VanDam selects crankbait colors based primarily on the water clarity.

“In Southern reservoirs, the shad are all shallow and some of the tributaries are going to be dirty,” he says. “That's when a color like **chartreuse sexy shad** or **gizzard shad** is going to be my choice because they have contrasting colors that stand out in dirtier water.”

As he switches to clear and slightly stained water, VanDam goes with more natural colors for crankbaits (but still sticks with the shad theme).

“One of my favorites for clear water is a color called **natural shad**, which is a print of an actual shad,” VanDam says. “It's a real good one and one of the most natural colors you can use. If it's just lightly stained, I like **summer sexy shad**, which is still natural but more visible at the same time.”

DeFoe also uses water clarity as one factor for selecting a crankbait color, and also considers wind and weather conditions.

"When the water is pretty clear and you have bright skies, I like a color that has a little flash to it," he says. "In the Rapala DT Series, the **green gizzard shad** is a good one and in the OG lineup, **live river shad** and **big shad** are great. They're good shad imitators and do better than a solid white color when the bass can get a better look at them." For windy or overcast days or when fishing dirtier water, DeFoe believes that contrast is essential.

"I like a bright color but one that also has contrasting colors," he says. "**Ike's penguin** in the DT Series or **original shad** in the OG lineup are great for those conditions."

## THE FALL-TO-WINTER TRANSITION MEANS CRAWFISH COLORS

As late fall slowly turns to winter, DeFoe and VanDam turn most of their attention to crawfish patterns.

"There's a point, usually when the water is in the mid- to low-50s, when I start to focus on cranking rocks as it gets colder," DeFoe says. "I'll fish crawfish colors more the later it gets in the year. When it gets down into the 40s, I'll be fishing these colors almost exclusively."

DeFoe is not too particular for crawfish crankbait colors and generally uses just one or two for most instances.



### SHAD PATTERNS FOR DIRTY/MUDDY WATER

- Rapala Ott's Garage Slim 06 in shad,
- Strike King KVD 1.5 Squarebill in char-
- treuse sexy shad, Strike King KVD 1.5
- Squarebill in gizzard shad, Rapala
- Custom Ink DT4 in Ike's penguin.

"If your bait is digging down in the bottom and scooting along making a dust trail, I don't think the specific crawfish color is that important," he admits. "**Dark brown crawdad** in the DT series and **crawdad** in the OG

Series are about all you need. They work when the water is clear or a little dirty and when it's sunny and cloudy."

DeFoe relies on these two crankbait colors almost exclusively unless he's faced with muddy water.

"That's when the red stuff like **red crawdad** and **demon** comes into play for me when the water is muddy,"

DeFoe says.

VanDam adjusts his crawfish patterns with more regularity and adjusts them primarily based on water clarity.



### CRAW PATTERNS FOR CLEAN/STAINED WATER

- Rapala DT4 in dark brown
- crawdad, Strike King Series
- 3 Crankbait in DB craw,
- Strike King 3XD Crankbait in
- green craw.



**CRAW PATTERNS FOR DIRTY/MUDDY WATER**

Rapala Ott's Garage Slim 06 in red crawdad, Strike King 3XD Crankbait in chartreuse belly craw, Rapala Custom Ink DT4 in Ike's Demon.

"Strike King has so many different crawfish patterns for their crankbaits and they're all good, but I have some favorites," he says. "When the water has a little color to it, **chartreuse belly craw** is a good one. When the water is clear, I like **green craw** or **DB craw**. I'll also pay attention if a bass has a crawfish in his mouth or spits one up so I can match it even closer."

**THE EXCEPTIONS TO THE RULE**

Crawfish hues are the way to go during the winter and spring months, but they have a place year-round and definitely in the fall, according to VanDam.

"There are certain lakes where a crawfish pattern is always going to work, no matter what the season," VanDam observes. "Table Rock comes to mind as well as places like Dale

Hollow. Lakes with a lot of natural rock, not riprap, are lakes that you can always fish a crawfish pattern crankbait even if they are eating shad."

Another exception to the shad-to-crawfish color debate is lake-specific, according to VanDam.

"There are lakes like we have here in Michigan where there are no shad and they're the exception to all of this," he says. "In the fall, I'm going to be cranking bluegill and perch patterns like Strike King's **bluegill** and **yellow perch** colors. Then, you have places like Lake Hartwell where you need to be cranking something that looks more like a blueback herring."

DeFoe sticks with the general rule of shad colors in fall and crawfish hues as it gets colder but is willing to break the rule if needed.

"I've seen bass chasing shad with water temps in the mid-40s, so I won't hesitate to throw shad patterns if I see that, even though all of the common thinking says to throw a craw color when it's cold," he says. "Then you'll have times where the water is warm and bass are spitting up crawfish left and right, so crawfish-colored crankbaits could work every month of the year. The key is to pay attention to everything that's going on around you and look for those little clues."

When it comes to crankbait colors in the fall-to-winter transition, two of the best to ever hold a crankbait rod each agree that shad-to-crawfish color changes go right along with the changing colors of leaves. But with everything else in fishing, there are exceptions to the rules, and it pays to keep tabs on what is happening around you and be willing to make slight adjustments based on water clarity and weather conditions. ■

***"THERE ARE CERTAIN LAKES WHERE A CRAWFISH PATTERN IS ALWAYS GOING TO WORK, NO MATTER WHAT THE SEASON."***



**PATTERNS FOR NORTHERN LAKES WITHOUT SHAD**

Strike King KVD 1.5 Squarebill in bluegill, Strike King Series 3 Crankbait in yellow perch.

1

## DAIWA ZILLION SV TW

\$349.99 | [daiwa.com](http://daiwa.com)

*"An ICAST winner that lives up to its billing."*

Daiwa's update to the popular Zillion platform won Best of Show at ICAST in 2021, and it's easy to see and feel why. The Zillion SV TW is built around the SV Booster System and four-part Hyper Drive Design that provide maximum casting distance, precise braking, excellent torque and outstanding overall performance.

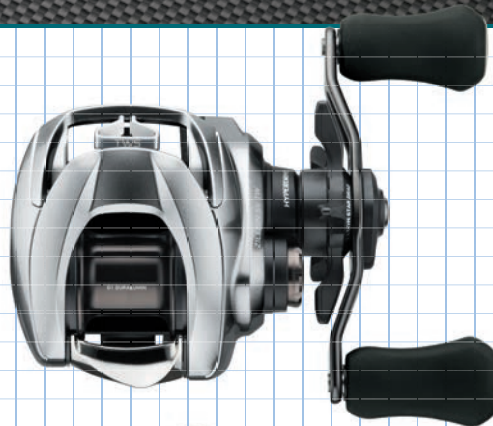

2

## FAVORITE FISHING SOLEUS XCS

\$179.99 | [favoriteusa.com](http://favoriteusa.com)

*"Looking for a reel that'll last a lifetime? This is the one."*

Favorite Fishing rolled out the Soleus XCS after two years of testing - at first blush, it was well worth the wait. Weighing in at 6.4 ounces thanks to duralumin components, the Soleus XCS is built on a durable aluminum frame which is dipped in copper, zinc, titanium and chrome (can you say "weatherproof?").



3

## SHIMANO CURADO MGL 150

\$199.99 | [fish.shimano.com](http://fish.shimano.com)

*"Light in weight and heavy on tournament-tested features."*

The MGL 150 is the lightest Shimano Curado reel to date thanks to its MagnumLite spool and compact 150 sizing. But it's not just about the weight for this powerhouse: The Curado MGL 150 is a seriously diverse reel built around tournament-tested Shimano features like the HAGANE Body, Cross Carbon Drag and X-Ship gearing system.

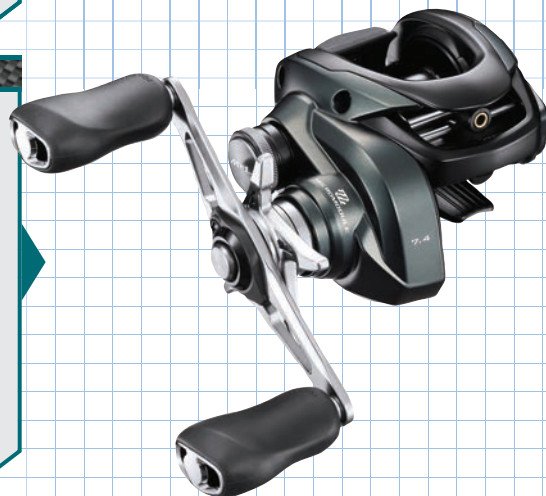

4

## LEW'S TOURNAMENT LITE LFS

\$249.99 | [lews.com](http://lews.com)

*"Lighter, faster, stronger and worth every penny."*

How difficult is it to engineer a light reel without compromising power? Very. Lew's nailed it with the new Tournament Lite LFS. Constructed with a one-piece aluminum frame and ultra-light C45 Carbon sideplates, the Tournament Lite LFS reel has a long list of features, but the bottom line is short and sweet: This reel is worth a look.



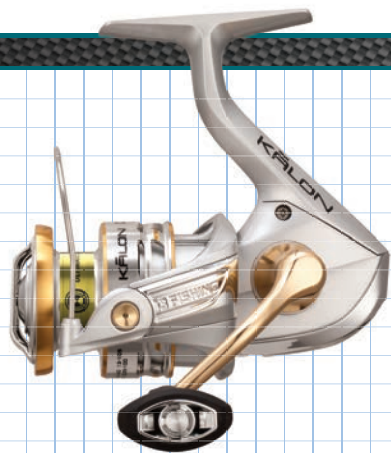

5

## 13 FISHING KALON C 6.2

\$89.99 | [13fishing.com](http://13fishing.com)

*“Speedy 6.2:1 gear ratio = more slack-line hookups.”*

The 13 Fishing Kalon C was engineered for versatility, performance and affordability – mission accomplished. The Kalon C’s foundation is 13 Fishing’s uber-smooth Ultimate Cut Aluminum Drive Gear and powerhouse drag system, but it also features Instant Stop Anti Reverse, a sealed rotor, the GLIDE Oscillation System and seven ball bearings for smooth reeling.



6

## QUANTUM SMOKE X 100

\$149.99 | [quantum.com](http://quantum.com)

*“Familiar Smoke balance and dependability.”*

The new lineup of Quantum Smoke X reels features the same aluminum Uni-body construction, Reel Engine Design (R.E.D.), and titanium bail wire that made the Smoke S3 such a winner. The Smoke X is highlighted by nine performance bearings, C4FL rotor and a ceramic-carbon fiber drag system that supply balance, smooth casting and the power to handle big fish.

7

## ABU GARCIA ZENON

\$499.99 | [abugarcia.com](http://abugarcia.com)

*“The absolute alpha spinning reel in your collection.”*

The Zenon is the alpha reel of the Abu Garcia spinning lineup, and while it comes with a \$499.99 price tag, we promise this is a once-in-a-lifetime reel that’s worth every penny. With a fast 6.2:1 gear ratio, 10 stainless steel HPCR bearings plus one roller bearing, the Zenon is one of the smoothest casts and quickest retrieves you’ll find in a spinning reel. Zenon combines a C6 V-Rotor and Ultra lightweight Air-Fin Spool with a one-piece magnesium body, all weighing in at under 5 ounces. Pair that with Abu Garcia’s AMGearing, Rocket Line Management System, Compact Bent Carbon handle and integrated drop-shot keeper, the Zenon is optimized for performance, inside and out. ■



**WE ARE GEARHEADS**



**WE ARE  
BASS FISHING.™**

**MLF MEMBERS GET  
25% OFF APPAREL  
& 15% OFF WATCHES  
BY LUMINOX**

***ShopMLF.com***



SWISS + MADE



# MAKE YOUR MOVE



**NEW**



Only Plano® EDGE™ Flex offers quick set dividers, allowing you to completely customize your storage. **It's time to up your tackle game.**

**PLANO**  
**EDGE**  
**FLEX**

PROFILE: **CLABION  
JOHNS**  
SOCIAL CIRCLE, GEORGIA



Clabion Johns was a “rookie” on the 2021 Tackle Warehouse Pro Circuit by only the strictest definitions. Sure, it was his first season fishing the national level, but the 39-year-old Georgia native has spent the last several years fishing more bass tournaments than just about anyone. One look at his Toyota Series and Phoenix Bass Fishing League resumes says it all: In 2020 alone, Johns fished 23 MLF tournaments (including the All-American and Toyota Series Championship) and has 14 career Top 10s to his name.

With nothing left to prove on the regional circuits, Johns brought his substantial talent to the Pro Circuit this season and announced his presence with authority, finishing seventh in Angler of the Year points en route to Polaris Rookie of the Year honors. “Consistent” and “steady” might be the best words to describe Johns’ season (if you exclude words like “successful” and “impressive”): five top-35 finishes in seven events, including the Tackle Warehouse TITLE in August, and it all culminated in a rookie season he’ll remember forever.

## Q&A

By Kyle Wood  
PHOTOS BY JODY WHITE

**Talking with you up at the St. Lawrence River where you locked up Polaris Rookie of the Year, your season goal was to qualify for the Bass Pro Tour and try to win Angler of the Year. You didn’t win AOY, but you got ROY and a Bass Pro Tour spot. How’s it feel to have accomplished that in your rookie season?**

Oh, it’s awesome. When I saw the schedule for this year, I knew I could do well. Making the Bass Pro Tour was my main goal, and I can’t wait for the opportunity to fish both that and the Pro Circuit next year. I still don’t think it’s sunk in yet, though.

**“Clabion” is an interesting name. Is it a family name?**

It’s my middle name, actually, and it’s actually a misspelling of “Clayborn,” but it’s a happy accident. I’m a junior, but I go by Clabion and I like it.

**There are anglers in this sport that really love fishing as many tournaments as possible because they think it helps them stay in the groove. Is that the mindset you have for next year in fishing the Bass Pro Tour and Pro Circuit?**

It'll keep me tuned in with what's going on in different areas of the country seasonally for sure. For example, if I'm fishing Eufaula or Seminole in the last week of May or first week of June and I've been there for a week and haven't seen a mayfly hatch, it's coming. I know it's coming. Keeping in touch with all that's going on makes you better in terms of tournament fishing.

**You're obviously ate up with fishing. How'd you get the bug?**

I can 100 percent thank my father, Russell, for that. He kept me on the water when I was really young. We'd walk around ponds on the weekend or scull a jon boat. I grew up fishing every possible way. Then I started fishing jon boat tournaments with my dad when I was 13.

**So, was your dad a tournament angler, too?**

No. Good God, no. He was a Turn hook, Culprit worm and a 3/8-ounce bullet weight guy. Fiberglass rod and a Mitchell 300 reel. That was him. He didn't own a baitcaster until 2007 and I had to teach him how to use it.

**Were you a very competitive kid growing up?**

I got really into skateboarding, music, chess, darts, pool and fishing growing up. Those were my passions.

**This season you went through some personal issues that took your mind off fishing for a bit. With that behind you now, how's it feel to be fishing with your mind 100 percent focused on fishing?**

I've always wanted fishing to be my full-time career and now that it's going to be, it'll keep me on my game. My mental state was off a bit (during the 2021 Pro Circuit), but now having my work responsibilities off of me, I feel

like there's a huge weight lifted off me. I now have an extremely strong support system and life is great. I'm in the best mood I've been in my whole life.

**Every time you come across the weigh-in stage, you're always holding a drink of some kind. What's up with that?**

It's a natural drink called Bing that's made out of cherry juice. I guess you could say it's like an energy drink, but it's not full of sugar. I'm an extremely healthy person. I don't drink sodas. I don't eat fast food. I live off veggies, salads and fish. You'll never see me drink anything other than coconut water, Bing drinks or coffee.

**When I think of Clabion Johns and bass fishing, I think of a frog. Why is that?**

I grew up fishing ponds and grew up with a Pop-R in my hand. I loved throwing a Pop-R. It was the greatest thing ever. When I was 12 years old, I started traveling to Eufaula a lot and it's full of grass and lily pads and I couldn't really throw my Pop-R where I wanted. I'd catch fish on it, but they'd pull me into the grass and come off and it got frustrating. I started looking into frogs and started throwing a Strike King Popping Pro Model Frog and caught fish on it and then when the Zoom Horny Toad came out, I started wrecking fish on it. Then, in 2007, the magic happened. Good popping frogs were available, and it was everything I wanted in a bait. But a popping frog changed my fishing to what I always pushed towards and could finally do it on any lake I went to.

**For a guy who has as much tournament experience as you do, you fit the mold of anglers who fish their strength and make it work across the country like a John Cox or Andy Morgan. How do you build that confidence to do what you want on any lake across the country?**

I guess I've amassed enough data points in this sport to know a bass is a bass is a bass. You can isolate certain factors, like structure, or what a bass is eating in a certain lake. If you do your

research before you get to a lake you've never been to and identify cover or structure you like – which for me is grass – and find areas that look like they should live there, they probably do.

**You're a great shallow fisherman. Do you have a weakness in your game right now, or something you want to get better at?**

Swimbait. It doesn't fit how I like to fish. I'll throw a hard wakebait, but I don't like swimbait. To me, I look for bass that are shallow and lazy. My fish eat gizzards, bluegill and crawfish. You'll never see me hurling an 8-inch swimbait. I'm not Steve Kennedy. It ain't going to happen. Swimbait is almost as bad as Senko fishing.

**You're saying you're not a finesse guy?**

Finesse to me is a full-sized Trick Worm on a 1/4-ounce shaky head. That's as finesse as I get.

**People know when you launch your boat in the morning because you tend to have music blaring, and I know I've heard your truck rocking out in the parking lot. What type of music do you like to listen to?**

I'm a metalcore guy. I was a guitarist in metalcore band for a long time. I enjoy having a bit of persona. You can look at me, look at my boat and know I'm not a normal fisherman. I don't fit in a normal niche. I'm just trying to do things my way. ■





# OUTDOOR ADVENTURER Prize Pack

FISHING KAYAK + PADDLE + COOLER + HAT + MORE!  
**ENTER TO WIN OVER \$2,000 IN PRIZES**  
[www.explorelacrosse.com/win-fun](http://www.explorelacrosse.com/win-fun)



## LUNKER LEAGUE

FISH LA CROSSE MASTER ANGLER PROGRAM

Lunker League celebrates anglers fishing in the La Crosse Region and the memorable fish they catch with goals, accreditation, and awards.



1. SNAP A PIC & MEASURE



2. UPLOAD YOUR CATCH



3. EARN CREDITS & WIN

JOIN AN ELITE LEAGUE OF ANGLERS TODAY!

Submit Your Qualifying Lunkers for FREE with Unlimited Entries!  
**14 Qualifying Species to Catch!**



SCAN ME



## TBF NATIONAL SEMI-FINAL SEASON IN FULL SWING

Opportunities abound for grassroots anglers to advance to national tournaments

**T**he Bass Federation (TBF) is gearing up for an extremely busy National Semi-Finals season this fall for 22 districts across the country. These Semi-Finals are close-to-home tournament opportunities that are held within a 500-mile radius of every corner of the contiguous United States, so they're accessible to anglers from coast to coast and border to border.

"These Semi-Finals allow grassroots anglers to fish close to home while qualifying for some of the

biggest tournaments in competitive bass fishing in TBF and MLF," said TBF president Robert Cartidge. "No matter where they live, anglers need to travel only as far as the state next door to compete in a Semi-Finals [event] and set them up for a chance to make it to the National Championship."

### THE FRAMEWORK

The Bass Federation National Semi-Finals offer 100 percent payback to both boaters and co-anglers, plus the opportunity to

earn additional prizes. One boater and one co-angler from each state advances out of Semi-Finals, but more can advance from each state depending on the size of the state's TBF membership base.

One additional boater and co-angler can advance from each state for every 40-boat milestone hit by the membership. Forty members sends one extra boater and co-angler to the National Championship, 80 gets two extra boaters and co-anglers, etc.

## 2021 SEMI-FINAL SEASON

Some 2021 Semi-Finals have already taken place as of this printing, with more in the fall. The top boater and co-angler from each TBF-affiliated club – along with qualifiers from their state federation – will compete in these Semi-Finals.

- The District 1 Semi-Final tournament – which includes boaters and co-anglers from Florida and Georgia – will take place October 9-10 on Lake Lanier in Georgia.
- North Carolina and South Carolina anglers will compete in the District 2 Semi-Final November 6-7 at Lake Murray, while District 3 (Kentucky and Tennessee) holds its tournament on Kentucky Lake October 16-17. Alabama and Mississippi will also fish their Semi-Final October 16-17 on Sardis Lake for District 4.
- Louisiana and Texas fished their Semi-Final September 25-26 for District 5 on Toledo Bend Reservoir, while Arkansas and Oklahoma wrapped up the District 6 Semi-Final on Lake Millwood on June 20. District 7 also held its Semi-Final October 2-3 on Wilson Lake for Kansas and Missouri boaters and co-anglers.



District 6 boater winner Steve Tyson.

• South Dakota, North Dakota and Nebraska make up District 8, which contested its Semi-Final on September 19 and District 9, made up of Iowa, Minnesota and Wisconsin completed its Semi-Final on Sturgeon Bay September 26.

- District 10's Semi-Final begins October 9 for Indiana and Illinois on Pool 19 of the Mississippi River.
- Michigan and Ohio completed their Semi-Final on the Detroit River September 26 for District 11 and the Semi-Final for District 12 – West Virginia and Virginia – was completed September 26 on Sutton Lake.
- Washington D.C., Delaware and Maryland make up District 13, which competed on the Potomac River October 2-3. District 14 consists of New York, Ontario and Pennsylvania; those anglers fished Lake George, New York in September.
- District 15 includes Connecticut, New Jersey and Rhode Island, which fished New York's St. Lawrence River in September, while District 16 (Massachusetts and Vermont) fished Lake Champlain in mid-September.
- Maine and New Hampshire anglers fished Lake Winnepesaukee in September for their District 15 Semi-Final. On the opposite coast, District 17 (Oregon and Washington) fished Tenmile Lake for its Semi-Final October 2-3.
- Idaho and Montana completed District 19's Semi-Final in late September on Noxon Reservoir. District 21 is made up of Colorado, New Mexico and Wyoming. That Semi-Final was fished in July on Navajo Lake.
- Nevada and Utah anglers fished Starvation Reservoir in June for the District 22 Semi-Final and, lastly, Arizona and California will fish Lake Havasu October 23-24 for District 23.



District 21 co-angler winner Amy Winegardner and first place boater Cody Miller.



District 22 first place boater Tucker Cappella.

## THE PATH TO THE NATIONAL CHAMPIONSHIP

The boaters and co-anglers who advance through the Semi-Finals will compete in the TBF National Championship where they can win cash prizes and qualify for the Phoenix Bass Fishing League All-American and the Living Your Dream prize package.

"These Semi-Finals fill a niche that nowhere else in the fishing industry fills," Cartledge said. "We operate in every state besides Hawaii and Alaska, and we take a lot of pride in that. We give anglers from New England to the West Coast the chance to qualify for the BFL All-American, a tournament they couldn't qualify for any other way."

You can register for your state's Semi-Final by visiting [BassFederation.com](http://BassFederation.com). Good luck to all the boaters and co-anglers competing and to those who have already advanced to the National Championship.

# 2021 HIGH SCHOOL STATE EVENT RESULTS

## Maine State Championship

July 18 – Crescent Lake

Zachary Morris, Colby Carrier and Tyler Williams

15 pounds, 5 ounces



Maine

## Michigan State Championship

July 25 – Hubbard Lake

Joey Elliot and Jacob Nickert

18 pounds, 2 ounces



Michigan

## North Dakota State Championship

August 14 – Lake Audubon

Logan Bullinger, Ryan Bullinger and Scott Bullinger

16 pounds, 8 ounces



North Dakota

## Pennsylvania State Championship

July 11 – Lake Oneida

Ty Stroup, Daniel Walter and Wes Walter

13 pounds, 10 ounces



Pennsylvania

## Vermont State Championship

July 18 – Lake Champlain

Brendan Vinton, Chase Martin and Anthony Vinton

18 pounds, 5 ounces. ■



Pennsylvania



## TBF CLUBS EARN CONSERVATION GRANTS FROM BASS FISHING HALL OF FAME

The Board of Directors for the Bass Fishing Hall of Fame (BFHOF) announced in August that they awarded four conservation grants to organizations that are preserving the sport of bass fishing. Three out of the four grantees are TBF organizations, showing TBF's dedication to not only the grassroots of competitive bass fishing, but ensuring there will be a future for the anglers of tomorrow.

"We are once again thrilled to be able to contribute to these worthy projects that should provide immediate impacts," said BFHOF President John Mazurkiewicz. "Habitat restoration and management, and other conservation efforts, are the lifeblood of our sport and are critical to bass fishing's future. These grants are all going to worthy recipients for the benefit of the wider community."

### THE THREE TBF GRANTEES ARE AS FOLLOWS:

- Southwest Iowa Fishing Team (Iowa Bass Federation) – The SWIFT Conservation Fish Habitat Project will place artificial fish habitat structures in lakes and ponds throughout southwest Iowa, utilizing materials that will benefit biodiversity without decomposing or otherwise negatively impacting the fisheries.
- Spring Bassmasters & Southern Colorado Junior Bass Club (Colorado Bass Federation) – Youth volunteers will create structures of chain, twine, cables and weight to sink approximately 100 cottonwood trees in the Valco ponds, adding much-needed fish habitat.
- Tri-County Bass Anglers (Indiana Bass Federation) – Youth volunteers will employ a habitat enhancement plan created by the Indiana DNR in Patoka Lake, utilizing Pennsylvania porcupine cribs, pallets, black bass nesting structures and Hoosier cubes.

Congratulations to those well-deserving Federations on their selection.

## ABOUT THE BASS FEDERATION

**THE BASS FEDERATION INC., (TBF)** is a member of the Freshwater Fishing Hall of Fame. TBF is owned by those we serve, and dedicated to the sport of fishing. The Federation is the largest and oldest organized grassroots fishing, youth and conservation organization. TBF, our affiliated state federations and their member clubs conduct more than 20,000 events each year and have provided a foundation for the entire bass fishing industry for more than 50 years. TBF founded the Student Angler Federation and the National High School Fishing program in 2007 to promote clean family fun and education through fishing, and are proud partners in fishing with MLF. Visit [bassfederation.com](http://bassfederation.com) or [highschoolfishing.org](http://highschoolfishing.org) and "LIKE US" on Facebook.

**Contact TBF:** Send us your club stories. If you have a question or want to know more about TBF, which is YOUR organization, drop us a line at [FAQ@bassfederation.com](mailto:FAQ@bassfederation.com). Above all else, thank you for being a member of The Bass Federation. ■

Statement of Ownership, Management and Circulation required by an act of August 12, 1970: Section 3685, Title 39, United States Code. Publication Title: Bass Fishing; Publication Number: 008-124; Filing Date: September 24, 2021; Issue Frequency: 6x/year – Dec/Jan, Feb/March, April/May, June/July, Aug/Sept, Oct/Nov. No. of issues Published Annually: 6; Annual Subscription Price: \$10.00; Mailing Address of Publication: 30 Gamble Ln., Benton, KY 42025; Contact Person: Michelle Dowling, 270-252-1604; Mailing Address of Headquarters: 30 Gamble Ln., Benton, KY 42025; Publisher: FLW; Editor: Joel Shangle; Owned and Managed by MLFLW, LLC, 30 Gamble Lane, Benton, KY 42025. Extent and Nature of Circulation: (a) Average No. Copies Each Issue During Preceding 12 Months; (b) Actual No. Copies of Single Issue (Aug/Sept 2021) Published Nearest to Filing Date. A. Total No. Copies Printed: (a) 21,506; (b) 21,307; B. Paid and/or Requested Circulation: 1. Outside-County Mail Subs: (a) 21,115; (b) 21,034; 2. In-County Subs: (a) 0; (b) 0; 3. Sales Through Dealers, etc.: (a) 0; (b) 0; 4. Other Classes Mailed: (a) 0; (b) 0; C. Total Paid Circulation: (a) 21,115; (b) 21,034; D. Free Distribution by Mail: 1. Outside County: (a) 0; (b) 0; 2. In-County: (a) 0; (b) 0; 3. Other Classes: (a) 0; (b) 0; 4. Free Distribution Outside Mail: (a) 0; (b) 0; E. Total Free Distribution: (a) 0; (b) 0; F. Total Distribution: (a) 21,115; (b) 21,034; G. Copies Not Distributed: (a) 391; (b) 273; H. Total: (a) 21,506; (b) 21,307; I. Percent Paid and/or Request Circulation: (a) 100%; (b) 100%.

# SUBSCRIBING HAS NEVER BEEN EASIER



Now it's even easier to sign up and receive a full year's subscription (6 issues) to Bass Fishing magazine. Join the country's most successful and avid anglers who enjoy all that Bass Fishing has to offer.

For quickest delivery, visit [MajorLeagueFishing.com/join](http://MajorLeagueFishing.com/join) or call 270.252.1000



Please allow 4-8 weeks for delivery of first issue.

# WORLD FISHING DESTINATION

*Lake Murray*

DISCOVER  
*South Carolina*

*Welcome*

Capital City  
**Lake Murray**  
Country

For all of your tournament needs, visit  
[LakeMurrayCountry.com](http://LakeMurrayCountry.com) or call 1-866-SCJEWEL.

Promoting Columbia, Lake Murray, Lexington, Newberry, Richland & Saluda.

# HOLD ON TIGHT TO YOUR DREAMS

**Q**uestion: What do you do when your real-life accomplishments exceed your childhood dreams?

Answer: No one knows. It never happens because we all have big dreams – huge dreams – and it would be almost impossible to outdo them. Whether you fantasize about winning Angler of the Year or hitting a walk-off home run in Game 7 of the World Series, our appetite for that kind of glory and accomplishment knows no bounds.

So, when Michael Neal won the 2021 Tackle Warehouse Pro Circuit Angler of the Year title and later raised the champion's trophy at Lake St. Clair in an MLF Bass Pro Tour event, one man's childhood dreams were coming true, but they're the tip of the fantasy iceberg. In fact, you could say that Neal had already done those things, many, many times ... in his head.

To have them come true in real life, with family, friends and fans watching, makes the dream more special, makes it something he can share, changes his hopes and dreams for the future, and makes him a kid again.

Though he's "just" 30 years old, Michael Neal was a very accomplished professional angler, even before winning these titles. For five consecutive seasons he finished in the top 20 of the Pro Circuit AOY standings. He finished fifth in his first Forrest Wood Cup (2013) and second in 2016. He's always been a threat, but until this year he didn't have the hardware to show it.

"I've been consistent, but I've never been able to win anything," Neal said shortly after winning AOY on the Pro Circuit. "Maybe winning Angler of the Year will free me up a little bit and let me fish a little more loose and not like I've got a chip on my shoulder. Hopefully, I can win an event or two. That would be the next box to check off."

Neal couldn't have known he would do exactly that – win his very next tournament, check that box, and set the stage for even more accolades – but he obviously had some newfound confidence. When asked if he would approach tournaments differently after winning AOY, he had a thoughtful answer.

"No, I'm trying not to have a very different approach going into practice, but I might do something different on the final day. I usually like to play it safer and not take gambles and risks instead of swinging for the fences. But to win, I'm going to have to start doing some of that more often."

He didn't need any last-minute heroics at St. Clair, but he was ready to gamble if necessary, and his new attitude paid off. The childhood dream of hoisting a champion's trophy was finally realized. Now there are more dreams

to realize and a bright future ahead for the budding star.

With his recent success, Neal joins the ranks of other greats who have made some of their dreams come true.

No one's won more tournament accolades than Kevin VanDam. Like Michael Neal, he dreamed of sports greatness, but imagined it would come on the baseball diamond before he ever thought it could happen through fishing. Early success fed KVD's confidence, and he's always maintained that if you believe in yourself, you can accomplish anything.

"Honestly, I'm surprised it's taken Michael so long to win," VanDam says. "He's extremely versatile, and no one on tour is surprised by his success. It's great to see such a good guy do well."

Edwin Evers won the inaugural REDCREST championship and knows a thing or two about making dreams come true.

"It can take a while for that kind of success to sink in," Evers says. "For me, I needed to sleep on it. When I woke up and realized it actually happened, that's when it hit me in almost equal parts of joy and relief."

To get meaningful advice on how to handle dreams coming true, you almost have to go to someone who's been there, like Evers.

"Sometimes everything just falls into place," Evers says. "Other times, you feel you're making all the right moves without having the same success. It's frustrating, and the joy can be short-lived. I hope Michael can enjoy and embrace it, but you can't allow yourself to be content with it."

We can also hope that Michael Neal will tap into his inner child now and then. After all, the boy is never very far from the man he grows into, and dreams do come true. ■



ILLUSTRATION BY JOE MAHLER

# LEW'S®



ANDY MONTGOMERY



KEVIN VANDAM



MARK ROSE



GREG HACKNEY



MARK ZONA

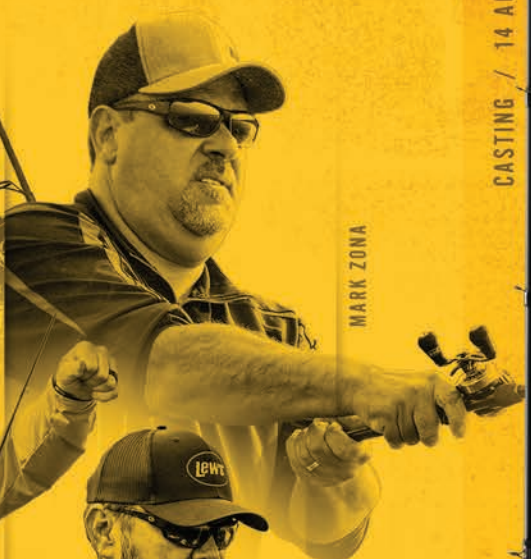

CASTING / 14 ACTIONS

SPINNING / 4 ACTIONS

# THIS IS OUR FOCUS GROUP

## THE NEW TEAM LEW'S® SIGNATURE SERIES RODS

Designed, developed and tested in collaboration with some of the top names on the water, the new Team Lew's Signature Series offers 18 models with specs and actions to cover a wide variety of styles and techniques. The Signature Series features the new, proprietary Winn® Dri-Tac Ultra grip, FOCAS™ High Modulus blank technology and a host of other key features—ultimately setting a new standard in performance within the Lew's rod lineup. Feel the difference!

/ LEARN MORE AT [WWW.LEWS.COM](http://WWW.LEWS.COM)



 Abu  
Garcia

**IT WILL HAPPEN  
ON CAST 2,873.  
OK, IT WILL HAPPEN ON CAST 2,874.**



**Anglers who tirelessly grind out long days on the water need equipment that goes the distance. Introducing the Veritas® Combos. The new Zata reels push the limits of high-performance gear with 11-bearing systems and lightweight frames. The 30 Ton graphite rods are built with Powerlux® resin, for stronger, lighter action cast after cast after cast.**

**FISH TO WIN™**